



Scalable Heterogeneous CPU-GPU Computations for Unstructured Tetrahedral Meshes

Johannes Langguth

High Performance Computing Department, Simula Research Laboratory, Oslo, Norway

3D Tetrahedral Mesh

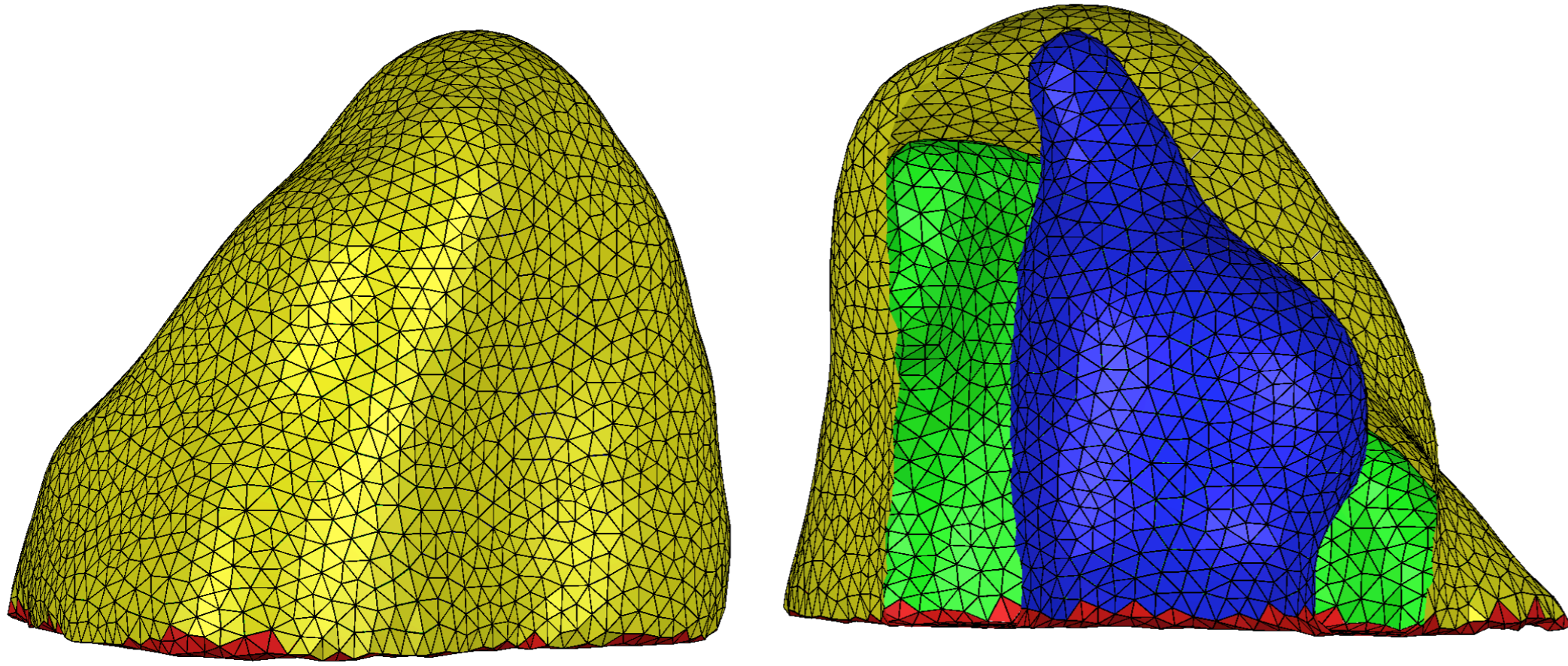

Heterogeneous Nodes

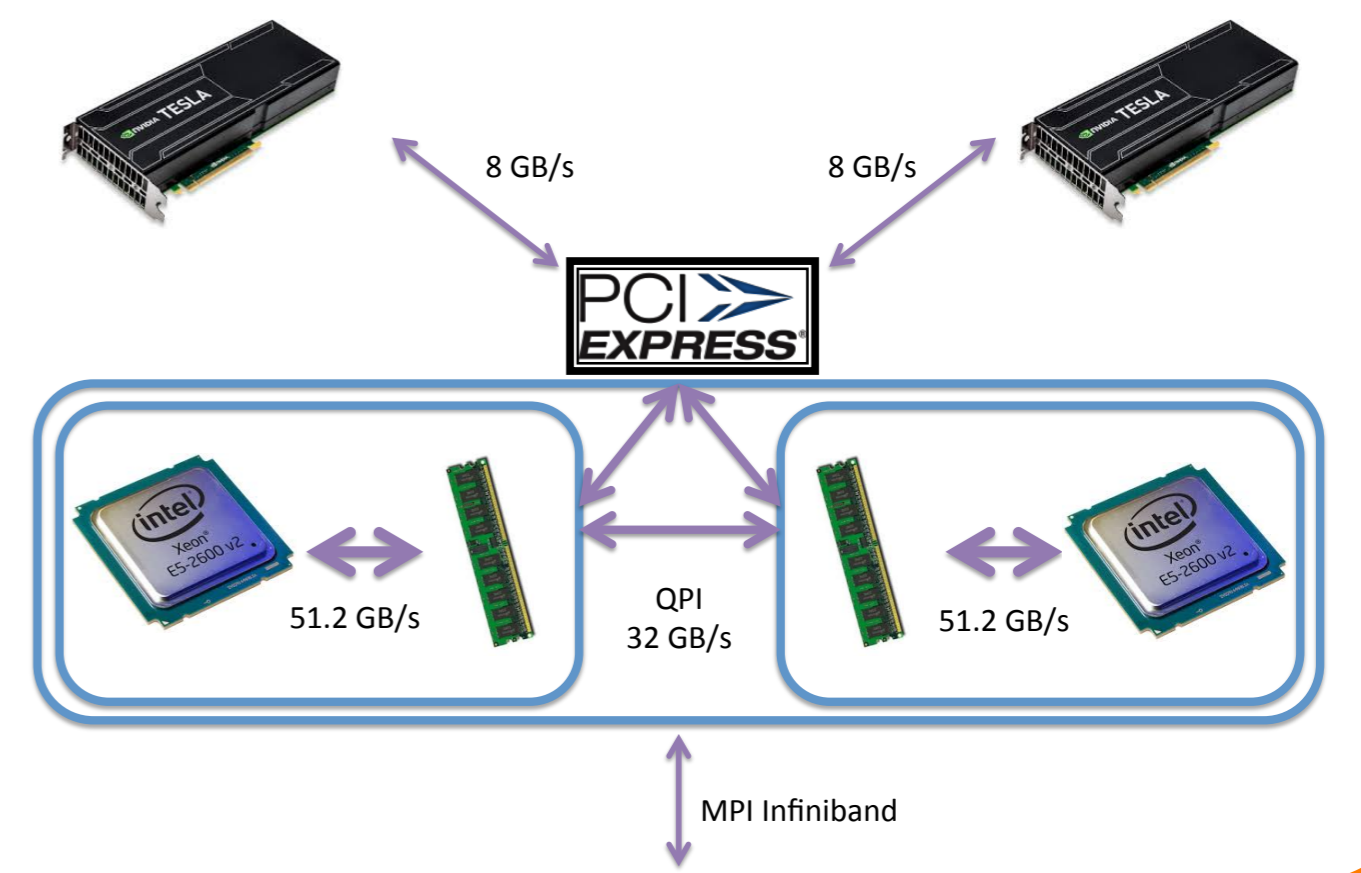

Partitioning

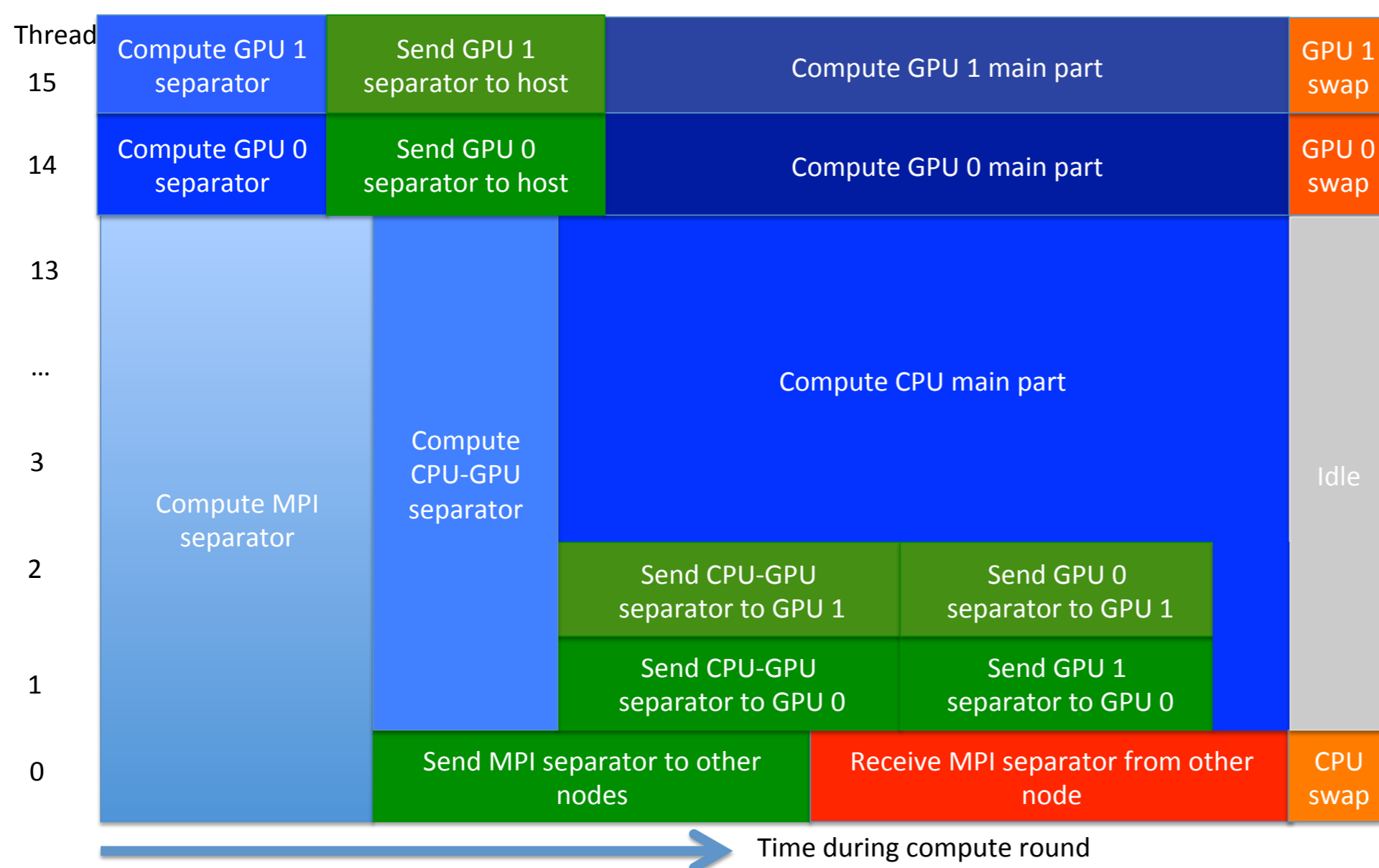
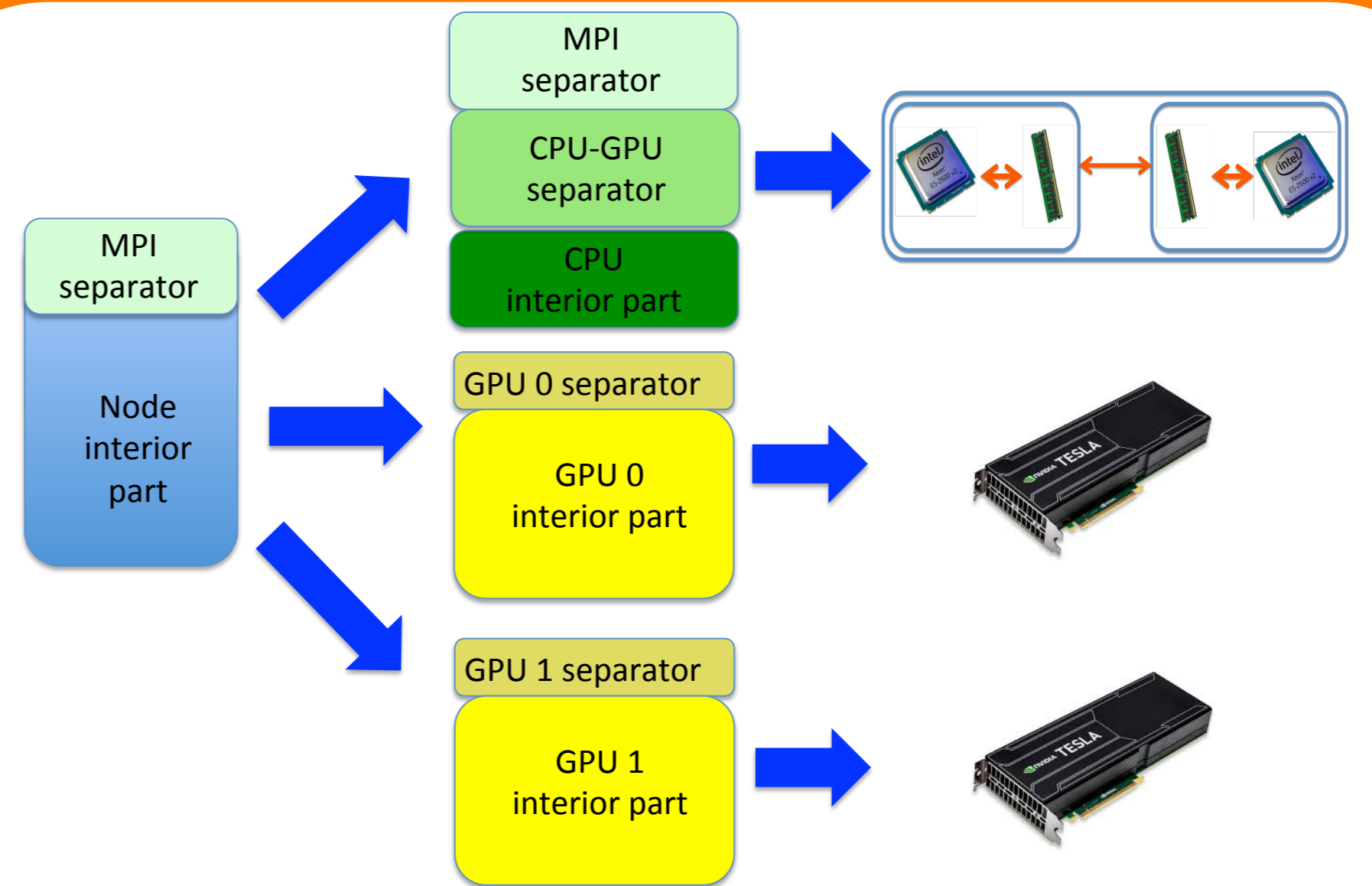
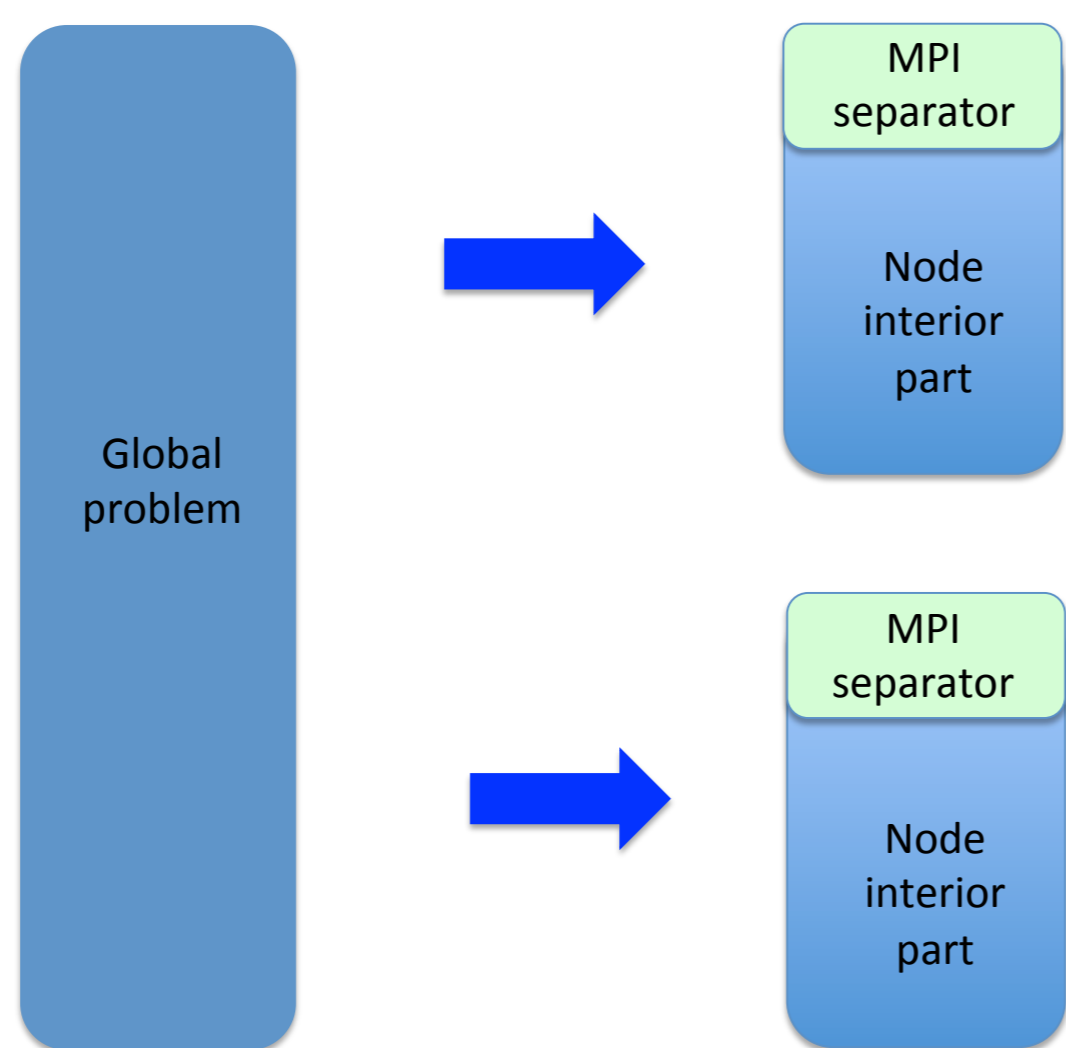

Scaling Performance

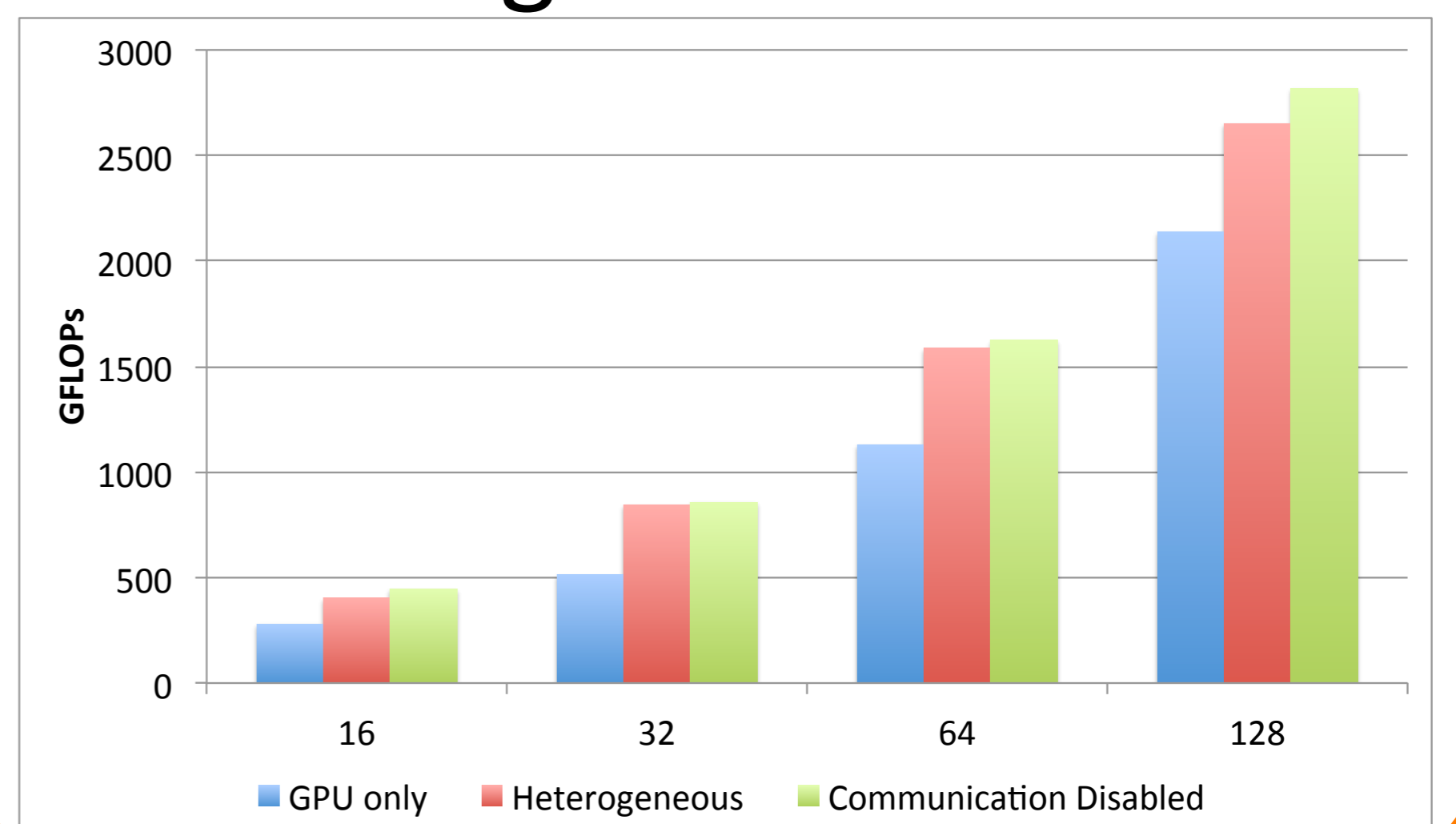

Calcium Handling

