



ACT Project Number:
271498

Project name:
ELEGANCY

Project full title:
Enabling a Low-Carbon Economy via Hydrogen and CCS

ERA-Net ACT project

Starting date: 2017-08-31
Duration: 36 months

D2.1.6 Solubility of H₂ in Brine at Reservoir Conditions

Date: 2019-06-30

Organization name of lead participant for this deliverable:
Imperial College London

| | | |
|---|--|---|
| ACT ELEGANCY, Project No 271498, has received funding from DETEC (CH), BMWi (DE), RVO (NL), Gassnova (NO), BEIS (UK), Gassco, Equinor and Total, and is cofunded by the European Commission under the Horizon 2020 programme, ACT Grant Agreement No 691712. | | |
| Dissemination Level | | |
| PU | Public | ✓ |
| CO | Confidential, only for members of the consortium (including the Commission Services) | |

| | |
|----------------------------|---|
| Deliverable number: | D2.1.6 |
| Deliverable title: | Solubility of H ₂ in Brine at Reservoir Conditions |
| Work package: | WP 2 CO ₂ transport, injection and storage |
| Lead participant: | ICL |

| Authors | | |
|--------------------------|---------------------|---------------------------------|
| Name | Organization | E-mail |
| Geraldine Torin-Ollarves | ICL | g.torin-ollarves@imperial.ac.uk |
| J P Martin Trusler* | ICL | m.trusler@imperial.ac.uk |
| | | |
| | | |
| | | |

*Mark Lead Author with asterix

| Keywords |
|------------------------------------|
| Brine; Hydrogen; Solubility; Water |

| Abstract |
|--|
| <p>The apparatus detailed in deliverable D2.1.4 has been employed to make measurements of the solubility of hydrogen in sodium chloride brine of molality 2.5 mol/kg (moles of salt per kg or water). Measurements have been made at temperature of 323.15, 373.15 and 423.15 K with various mole fractions of dissolved H₂, leading to bubble pressures up to about 40 MPa. This report details the results obtained which show a salting out effect of about 25%.</p> |

TABLE OF CONTENTS

| | Page |
|---|------|
| 1 INTRODUCTION..... | 1 |
| 2 EXPERIMENTAL MEASUREMENTS..... | 2 |
| 2.1 Resume of experimental system and procedure | 2 |
| 2.2 Experimental results | 4 |
| 3 CONCLUSIONS | 6 |
| 4 REFERENCES | 7 |

1 INTRODUCTION

Reliable knowledge of the thermophysical properties of mixtures of CO₂ and numerous other substances are essential in designing the overall process of hydrogen production from fossil fuels with simultaneous capture, transportation and storage of CO₂. Captured CO₂ is never pure, and, in this process, hydrogen is likely to be a significant impurity. This will affect the properties of the CO₂-rich stream during pipeline transportation and influence the storage behavior once the fluid is injected into a storage reservoir [1]. In the case of aquifer storage, the key components of interest are CO₂, impurities including H₂, water, salts and the reservoir minerals with which these fluids are in contact. In the ELEGANCY project, one of the objectives is to improve the available thermodynamic-property models to encompass hydrogen and other impurities both under the conditions of pipeline transportation and under aquifer-storage reservoir conditions.

The specific objectives of Task 2.1 “Thermodynamic property model for CO₂-brine” are to:

- Study the solubility behavior of CO₂ + H₂ in water and brines at reservoir conditions
- Develop a thermodynamic-property model to represent both this solubility behavior and the thermodynamic properties of the coexisting phases.

This report addresses the measurement of H₂ solubility in sodium chloride brine and includes experimental results at temperatures of 323.15, 373.15 and 423.15 K with various bubble pressures up to about 40 MPa.

2 EXPERIMENTAL MEASUREMENTS

2.1 Resume of experimental system and procedure

The experimental apparatus developed in this project is detailed in D2.1.4. Figure 2.1 is the PFD of the measurement system built up around a bespoke high-pressure view cell.

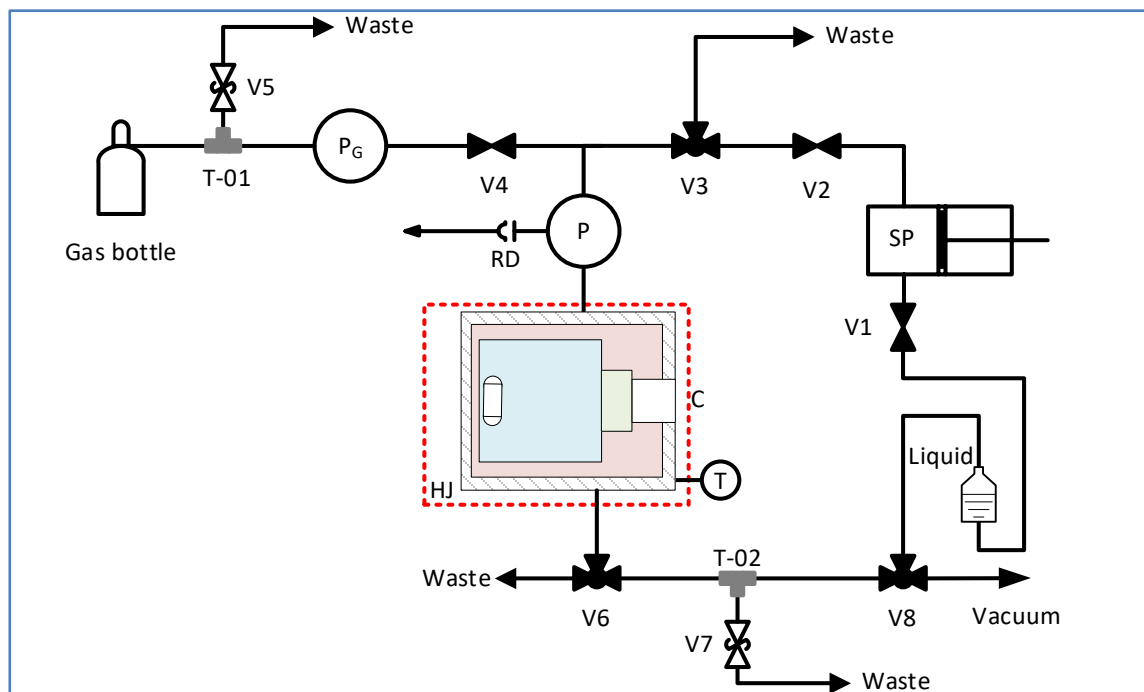

Figure 2.1: PFD of the system. SP, syringe pump; P_G & P, pressure sensors; T, temperature sensor; HJ, heating jacket; C, camera; RD, rupture disk; V1, V2, pump fill and dispense valve; V3, V4, V6, V8, manual valves; V5 & V7, proportional relief valves.

The standard operating procedure (SOP) for the experiment on H_2 solubility in brine, starting with a clean and evacuated system, was as follows (with reference to Fig 2.1):

1. Fill the liquid bottle with the brine solution and degas under vacuum.
2. Set the desired operating temperature.
3. Close V2, open V1 and allow the brine solution to flow into the evacuated pump.
4. Close V1, raise pressure in the pump and purge to waste through V2 and V3. Refill the pump through V1.
5. Isolate the outlet of the cell at V6 and isolate the liquid inlet at V3.
6. Slowly open V4 and admit gas until a pre-determined filling pressure is reached.
7. Allow the system to reach equilibrium and record the cell temperature and the pressure of the gas (measured with P_G).
8. Turn on the stirring mechanism, open valve V2 and V3, and start to transfer liquid into the cell.
9. When the cell is nearly filled with liquid, stop the transfer of liquid and continue stirring until the system reaches equilibrium in the two-phase region. At this point there should be a small bubble of gas remaining.
10. Proceed with further small injections of liquid (e.g. 0.2 mL) and equilibration periods until the bubble is completely dissolved.

11. Make a few further injections to raise the pressure in the single-phase region.
12. At the conclusion of the measurement, discharge the cell contents to waste through V6. The cell temperature may also be elevated above the boiling point of water to help empty the cell.
13. Repeatedly fill the pump and vessel with pure water to flush out residual salt.
14. Finally, evacuate the system, through V6 and V8.

This SOP is slightly different to the one described in D2.1.4 for CO₂ dissolution; the modified SOP was found to be more suitable for sparingly-soluble gases such as H₂.

To determine the bubble point, the equilibrium pressures recorded in steps 9 to 11 can be plotted against the volume of water injected as illustrated in Figure 2.2. The intersection of regression lines in the two-phase and single-phase regions identifies the bubble pressure. The amount of gas present is determined from the initial filling pressure and temperature and the amount of water present at the bubble point is determined from the volume V_{in} injected and the temperature and pressure in the syringe pump. Hence the bubble pressure and composition are both determined. Here, the single-phase region is fitted with a linear function of V_{in} while the two-phase data are fitted to a quadratic.

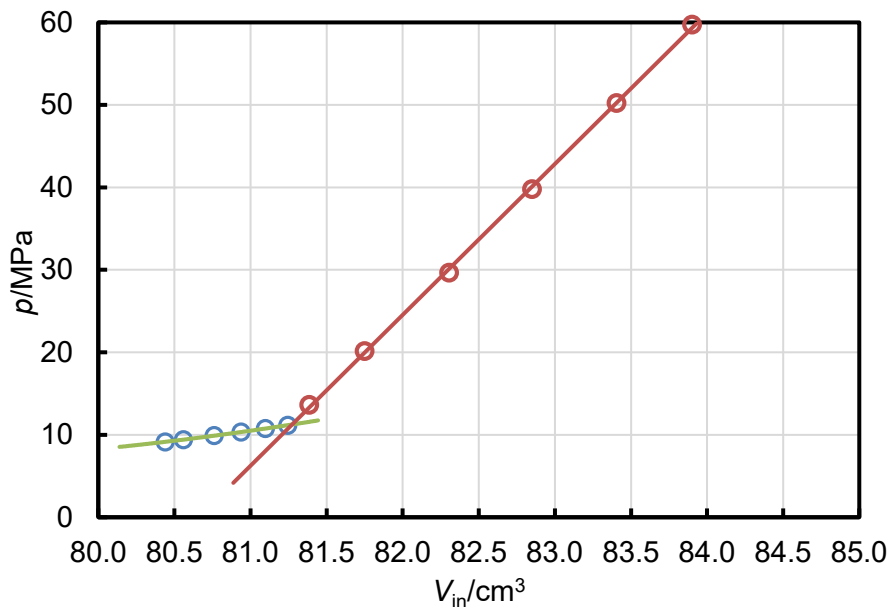

Figure 2.2: Pressures in the two-phase and single-phase regions for H₂ solubility in NaCl brine. Symbols: ○, experiment (two phases); ○, experiment (one phase). Solid lines: regression functions.

An alternative plot which can be used for the same purpose is shown in figure 2.3. The advantage of this plot is the pressure in the two-phase region are nearly linear in V_{in} , while those in the single-phase region are the inverse of a linear function. This makes the fitting of the data more reliable.

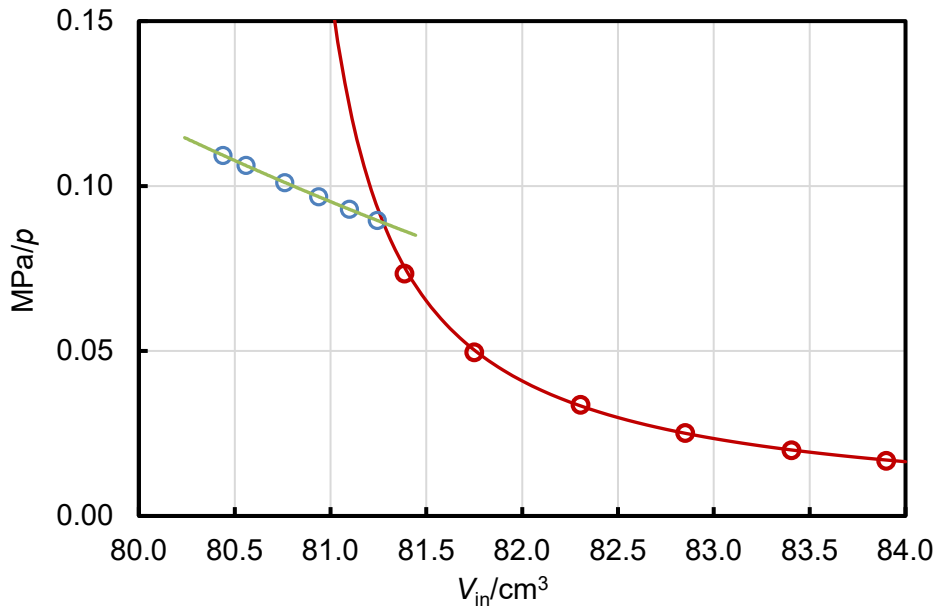

Figure 2.3: Inverse of the pressures in the two-phase and single-phase regions for H_2 solubility in NaCl brine. Symbols: \circ , experiment (two phases); \circ , experiment (one phase). Solid lines: regression functions.

2.2 Experimental results

Experiments have been performed at $T = (323.15, 373.15 \text{ and } 423.15) \text{ K}$ with various initial gas filling pressures and a NaCl brine of molality $b_s = 2.5 \text{ mol/kg}$. The raw data obtained are typified by those plotted in Figures 2.2 and 2.3. Table 1 lists the experimental results obtained for the bubble pressures at each composition studied and the results are plotted in Figures 2.4 in comparison with literature data for H_2 solubility in pure water. Also shown in Figures 2.4 are our earlier measurement for H_2 solubility in pure water. These results indicate that additional of 2.5 mol/kg of NaCl reduces the solubility of H_2 at given temperature and pressure by between 20% and 35%, depending upon temperature.

Table 1. Experimental solubilities of H_2 expressed as salt-free mole fractions x'_2 and equivalent molalities b_2 in NaCl(aq) of molality $b_s = 2.5 \text{ mol}\cdot\text{kg}^{-1}$ at temperatures T and bubble pressures p_b , where $u(p_b)$ is the standard uncertainty of p_b .

| T/K | $10^3 x'_2$ | $b_2/(\text{mol}\cdot\text{kg}^{-1})$ | p_b/MPa | $u(p_b)/\text{MPa}$ |
|--------------|-------------|---------------------------------------|------------------|---------------------|
| 323.15 | 1.099 | 0.0611 | 12.01 | 0.18 |
| 323.15 | 2.212 | 0.1231 | 26.23 | 0.31 |
| 323.15 | 3.410 | 0.1900 | 39.47 | 0.48 |
| 373.15 | 1.148 | 0.0638 | 11.64 | 0.08 |
| 373.15 | 2.347 | 0.1306 | 22.94 | 0.19 |
| 373.15 | 2.873 | 0.1599 | 27.76 | 0.40 |
| 373.15 | 4.242 | 0.2365 | 45.81 | 0.10 |
| 423.15 | 1.724 | 0.0959 | 14.94 | 0.47 |
| 423.15 | 4.557 | 0.2541 | 38.73 | 0.52 |

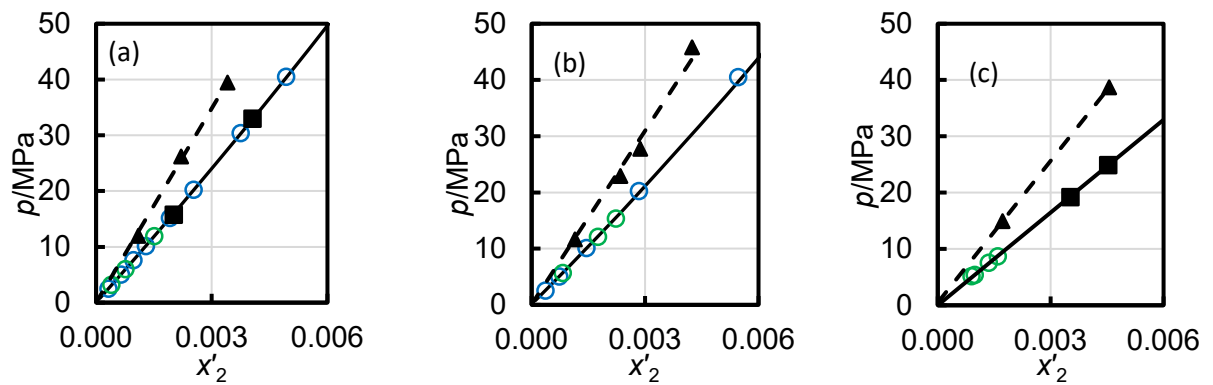

Figure 2.4: Comparison with literature data of H_2 solubility in water and brines. Symbols: \circ , Wiebe and Gaddy [2]; \odot , Kling and Maurer [3]; \blacksquare , \blacktriangle , this work in water and sodium chloride brine (2.5 mol/kg), respectively at temperature conditions of: a. $T = 323.15$ K, b. $T = 373.15$ K, and c. $T = 423.15$ K. Solid lines: regression functions. Lines are linear regressions (solid for solubility in water, dashed for solubility in brine).

3 CONCLUSIONS

The salting-out effect of NaCl on the solubility of H₂ in aqueous solution has been quantified for a salt molality of 2.5 mol/kg. The measurements extend over a wide range of pressure at temperatures of 323.15, 373.15 and 423.15 K.

4 REFERENCES

- [1] J.P.M. Trusler, Annual Review of Chemical and Biomolecular Engineering 8 (2017) 381-402.
- [2] R. Wiebe, V.L. Gaddy, JACS 56 (1934) 76-79.
- [3] G. Kling, G. Maurer, J. Chem. Thermodyn. 23 (1991) 531-541.