



Electric Infrastructure for Goods Transport

# Energy and infrastructure - demands and requirements

**AUTHORS**

Ola Rennemo	SINTEF Technology and Society
Odd Andre Hjelkrem	SINTEF Technology and Society
Terje Kristensen	SINTEF Technology and Society
Jon Suul	SINTEF Energy Research
Peter Brauhaus	IRIS
Arne Aamodt	Lyse

2018

## Table of contents

<b>1</b>	<b>Background</b>	<b>5</b>
<b>2</b>	<b>Method for estimating energy demand per vehicle</b>	<b>6</b>
2.1	Route definition	6
2.2	Speed profile generation	6
2.3	Vehicle model	7
<b>3</b>	<b>Estimated energy demand per vehicle</b>	<b>11</b>
3.1	Baseline	11
3.2	Electrification without external power	12
3.3	Electrification with external power in ascents	12
3.4	Electrification with power added on flat road	13
3.5	Extended road electrification	14
3.6	Conclusions from vehicle perspective	14
3.7	Vehicle battery savings	15
<b>4</b>	<b>Further developments of the energy calculation model</b>	<b>16</b>
4.1	Accuracy and new applications	16
4.2	New components	16
4.3	Software environment	16
4.4	Emissions and total economy	16
<b>5</b>	<b>Traffic volumes and energy demand on coastal highway E39</b>	<b>17</b>
5.1	Estimating traffic volume	17
5.2	Monthly and daily variations in the traffic volume	19
5.3	Estimating the energy demand	22
5.4	Summary	22
<b>6</b>	<b>Grid load and capacity</b>	<b>23</b>
6.1	Simplified grid loads	24
6.2	Cost estimates for grid investment (cost for grid companies)	25
<b>A</b>	<b>Vehicle economy using electrified road</b>	<b>27</b>
<b>B</b>	<b>Energy calculations</b>	<b>28</b>



# 1 Background

The purpose of WP3 is to develop a model for calculating power and energy requirements for vehicles. It should cope with different vehicle types and configurations, and use factors we know affects the results, such as road topography and speed profile.

Much of the literature in this field refers to vehicle energy requirements in litres per km, or Mega Joules (MJ) per km. The problem is that this information is valid only for one vehicle doing one specific drive-cycle. Any changes in topography, speed profile, weight or other factors will give other results. These numbers cannot be transferred to other situations, and this is a problem when looking at the effects of changes in road geometry, driver behaviour and vehicle improvements. By changing the focus to more fundamental factors like geometry, speed profiles and drivetrain efficiency, a more adaptable model can be developed. The simplest approach to calculating a route in more detail is to analyse each road segment by itself, assuming constant speed and load, and then add all results. In many cases this is fine, but the method hides the real utilization of engine and brakes (including regenerative brakes), and will not produce a realistic speed profile. The method described here uses output speed from one short segment as input speed to the next short segment. This assures that the effects of varying speed preferences and road geometries can be expressed. Speed profile and engine/brake load along geometrically equal road segments will vary a lot with the properties of the preceding segments, being uphill, downhill, roundabout or other, so the ordering of segments is important.

The recent improvements in national roads databases and speed preference models make such a detailed calculation model both possible and practical. Besides better calculations of total energy and fuel consumption, it is also possible to see where along the route fuel is spent. This information is important for assessing the need for charging of electric vehicles but could also be useful for studying local emissions and noise.

Power and energy requirements are especially important when it comes to electric vehicles. Increasing the capacity of a heavy electric vehicle is expensive, and over-investing is bad for business. On the other side, under-investing can make a vehicle useless. These results are also interesting when planning supporting infrastructure. It can give clues to how much energy is needed where, and at what rate.

We decided to use the E39 road as an example, because this road has a varied geometry, with flat parts, up-hills, down-hills, bridge crossings and underwater tunnels. This will challenge any heavy vehicle drivetrain, which makes it a good test for a detailed calculation method. The work done in WP3 builds on other activities and sources:

**NRDB** (National Roads Database): A service maintained by the Norwegian Public Roads Administration (NPRA), which includes description of all roads in Norway, with numerous attributes. This is the data source for road centrelines, speed limits, widths etc. **Fartsmodell for næringslivets transporter** (Speed Model for Commercial Transports): SINTEF report A17524, model documentation. A project to estimate free-flow speeds for heavy vehicles, and is the source for the implemented speed model. **RTM** (Regional Transport Models): An ongoing project for NPRA, looking at methods and tools for the regional transport models. These models are used to estimate traffic flows, speed and emissions from all transports. The calculations model discussed here, builds on work done in this project. **TNExt** (Transport Network Extension): A software extension to ArcMap, and part of the RTM project. It is used is to prepare and manipulate road network data from NRDB. Its primary application is to edit and prepare current and future road networks for transport modelling software. Routes and segments used here have been produced with TNExt.

## 2 Method for estimating energy demand per vehicle

The first step was to establish the road network. Export files from NRDB covering the region was read into TNExt, producing a geodatabase with road nodes and links with necessary attributes. Then geometries of planned roads were added into scenarios. Some of these geometries had to be adjusted for missing height values and misplaced connection points. Without these adjustments, the route definition process would fail, and calculations would give strange results. Then new and old roads were combined into a complete road network, and routes could be defined.

### 2.1 Route definition

The basis for the calculations is the routes, and they were defined using TNExt public transport route functionality. Each route is defined as an ordered list of road link geometries, forming a continuous 3-dimensional centreline from start to stop. Values for horizontal radius and vertical slopes were derived from the geometries. Values for speed limits and road widths follow the road links from NRDB as attributes.

The route definition is used in two different stages:

- 1) As input to the speed model for heavy vehicles, giving an estimate of preferred speed along the route.
- 2) As input to the energy calculation, which together with preferred speed, weight and resistance coefficients, gives required power on the wheels along the route.

The speed model and the energy calculations are based on specific values for the relevant parameters, meaning that the road segments in question must be uniform. But some of the parameters, like horizontal radius and slope, change continuously. The simple solution to this is to break the route into segments that are so short that the parameters have near constant values, and then calculate them one by one. This figure illustrates the first step in the process:

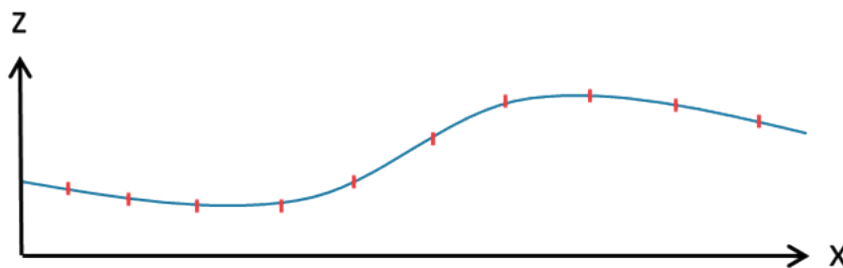
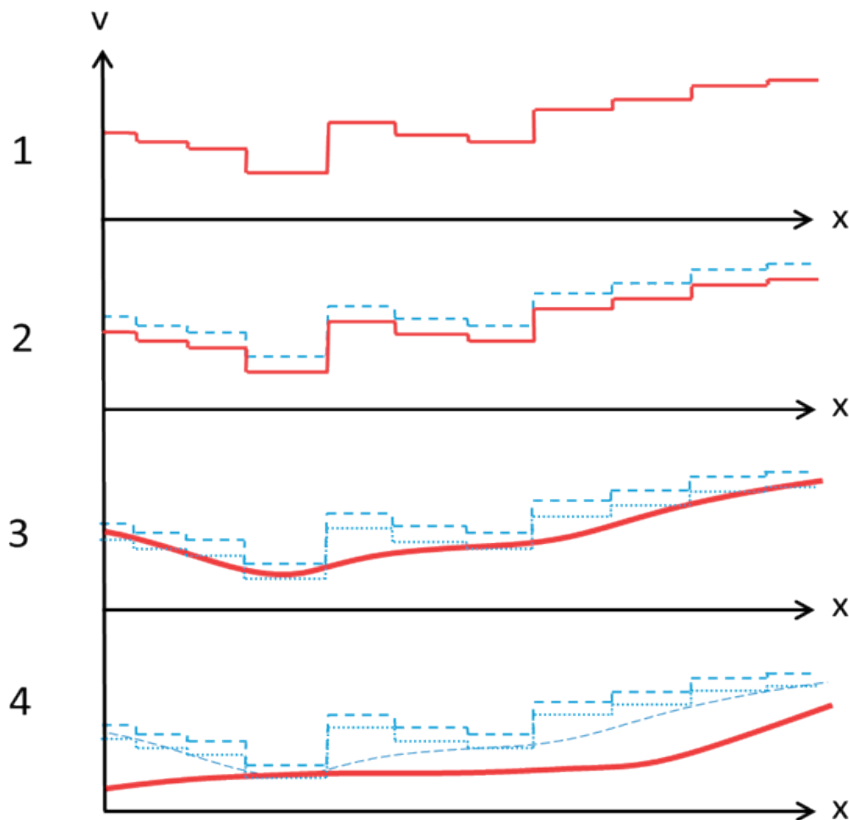

Figure 1 Vertical profile and segmentation.

### 2.2 Speed profile generation

After the segmentation, each segment's preferred speed is calculated independently. If traffic data is available, capacity curves can be used to pull down expected speeds on affected segments. The result is a speed profile with sudden and unlikely changes from segment to segment. To create a realistic speed profile, the speed levels are adjusted based on neighbouring segments and driver acceleration preferences. This gives a continuous and drivable speed profile representing what the driver is trying to do. Lastly, the physics module will verify or correct the result, trying to drive through the route at estimated speeds with the defined vehicle. Figure 2 illustrates the process:



**Figure 2 Speed profile adjustments: (1) Using speed model on each segment, (2) Possible correction due to congestion, (3) Damping using neighbour segments and driver preferences, and (4) Correction with vehicle limitations.**

## 2.3 Vehicle model

As the last step in figure 2 shows, information about the vehicle model is used in a calculation process, or vehicle model, to validate or correct the anticipated speed profile.

The vehicle model contains data like:

- Total weight [kg]
- Rolling resistance coefficient [-]
- Frontal area [m<sup>2</sup>]
- Aerodynamic drag coefficient [-]
- Engine power [kW]
- Brake power [kW]
- Accessory power [kW]
- Drive-train efficiency [-]

With the anticipated speed profile, detailed route and vehicle information available, Newton's second law of motion is used to calculate necessary power for each segment. Incoming and outgoing speeds might be reduced to keep the power requirements within the vehicle's limitations. The result is a speed profile that is both plausible and reachable for the specified vehicle.

The total work required to bring the vehicle from start to end of the route is simply the sum of power\* time for each segment.

To find the energy consumption seen from the tank, one has to include the drivetrain efficiency. Generally, efficiency is defined as the ratio between useful work and input energy:

$$\eta = \frac{W_{out}}{E_{in}}$$

If we use the efficiency for the entire drivetrain, then energy consumption can be calculated:

$$E = \frac{W_f}{\eta_f}$$

Here  $W_f$  is the work done by the drive wheels to bring the vehicle forwards, and  $\eta_f$  is the tank to wheel efficiency when doing so.

The process can be illustrated with this figure:

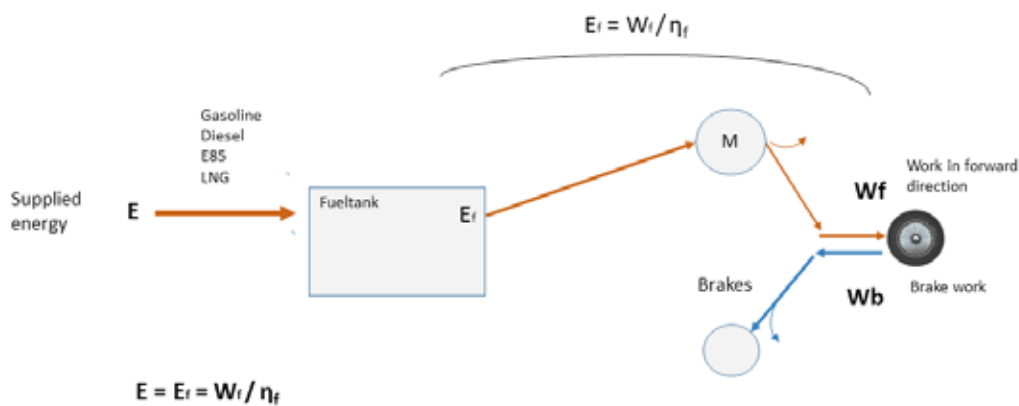

**Figure 3 Energy flow in drivetrain.**

The problem with  $\eta_f$ , and most other efficiency coefficients used here, is that they are not available from the supplier. But they can be estimated from tests. For approximate calculations on heavy diesel trucks, a value of 0.35 seems to be suitable.

This value will give too high consumption under heavy load, and too low consumption under light load conditions. The obvious reason is that the efficiency varies with the load. Defining efficiency as a function of relative load seem to give more accurate results.

An electric drivetrain can be described in almost the same way. One obvious difference is the use of regenerative brakes. If we define a regeneration efficiency coefficient  $\eta_b$ , the recovered brake energy can be expressed like this:

$$E_b = W_b * \eta_b$$

The losses when charging the vehicle can be considerable, and should also be included when looking at the total picture. This can be done by defining a charging efficiency coefficient  $\eta_c$ .

The following figure illustrates the energy flow in an electric drivetrain:



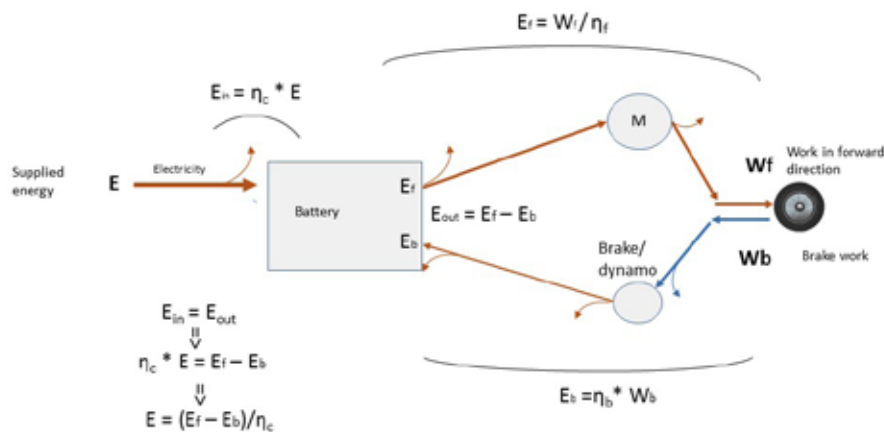

**Figure 4 Energy flow in an electric drivetrain.**

Assuming that battery status is the same before and after use and charging, the energy consumption can be expressed as  $(E_r - E_b) / \eta_c$ . If expressed using the calculated work and defined efficiencies, and adding accessory power consumption (ventilation, heating, cooling e.t.c.) named  $E_{acc}$ , the equation will look like:

$$E = \frac{(W_f / \eta_f) - (W_b \cdot \eta_b) + E_{acc}}{\eta_c}$$

Accessory energy consumption is included because it becomes relatively more important with improved engine efficiencies. This formula indicates that all available braking energy is regenerated. For small vehicles this is mostly true, but for heavy vehicles  $E_b$  should be calculated with restricted regenerative power.

The efficiency of the electric engine together with its inverter,  $\eta_i$  is high, and near constant during normal driving. Typical values seem to vary around 0.9. But processes within the battery will reduce it. A battery is often described as an ideal voltage source in series with a resistance. If doing so, it is assumed that the battery can supply any required current, and the added loss in power can be expressed like this:

$$P_{loss} \sim R_i \cdot I^2$$

where  $R_i$  is the internal resistance in Ohms, and  $I$  is the current flow in Amperes. To make things more complicated,  $R_i$  varies with temperature, state of charge (SOC) and wear.

One approach to the added complexity is to keep the equation as it is, and include these new losses by reducing the value of  $\eta_i$  to for example 0.8.

The same can be said for  $\eta_b$ .

Like the case with ICE drivetrains, one should know that this simplification may hide interesting details. The energy loss due to  $R_i$  can then be expressed as  $P_i \cdot dT$ , or  $R_i \cdot I^2 \cdot dT$ , where  $dT$  is the time interval where the current  $I$  is flowing. This is illustrated in the following figure:

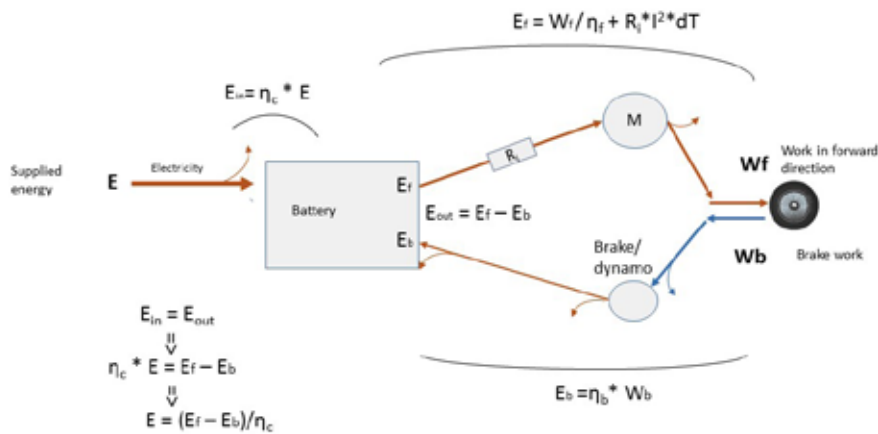

**Figure 5 Electric drivetrain with internal resistance.**

The extra energy loss can be corrected for by adding it to the total consumption:

$$E = \frac{(W_f / \eta_f) - (W_b \cdot \eta_b) + E_{acc} + R_i * I^2 * dT}{\eta_c}$$

To use this formula, one needs information on  $R_i$  and battery voltage, and then calculate  $I$ . Then it must be applied to every segment along the route.

When dealing with time variable factors, it is easier to express this per time unit, i.e. as power:

$$P = \frac{(P_f / \eta_f) - (P_b \cdot \eta_b) + P_{acc} + R_i * I^2}{\eta_c}$$

Then  $E$  can be calculated as the sum of  $P * dT$  for all segments along the route.

## 3 Estimated energy demand per vehicle

### 3.1 Baseline

As a baseline, a 42-ton 300kW diesel-powered vehicle is used from Stavanger to Bergen along the planned road. A net weight of 42 tons were chosen to be representative of an average weight, in contrast to the maximum allowed weight of 50 tons. However, for a vehicle of this type, weights would likely vary from 50 tons (max load) to 22 tons (empty).

Accessory power is set to 3kW. Total distance is 183 km, mostly flat road, but also including two deep underwater tunnels. Below is the computed result:

**Table 1 Model explanation**

Model colour	Model
Green	Speed profile without limitations
Red	Speed profile with vehicle limitations
Orange	Engine power delivered
Blue	Brake power
Black	Vertical profile



**Figure 6 Diesel truck from Stavanger to Bergen. Larger print on page 28.**

From left to right, the vehicle follows the terrain (black line) while trying to keep up with the green speed profile. The result is the red line. Details from the tunnels shows that the ascents are challenging for heavy vehicles, with ascent speeds of 30 to 40 km/h:

For a diesel configuration from Stavanger to Bergen:

- Total forward work on wheels = 297 kWh
- Total brake work on wheels = 80 kWh
- Fuel consumption = 0,4 litre/km (Based on a variable efficiency between 0.2 and 0.43)

### 3.2 Electrification without external power

As an example, equipping the same truck with 4 pcs 85 kWh Tesla batteries in parallel will add approximately 2 tons of weight, and give an internal resistance of about 0.03 Ohms at 400 Volts. Regenerative brakes are set to maximum 100 kW power, and 90% engine/inverter efficiency.

Purple line is battery input power.

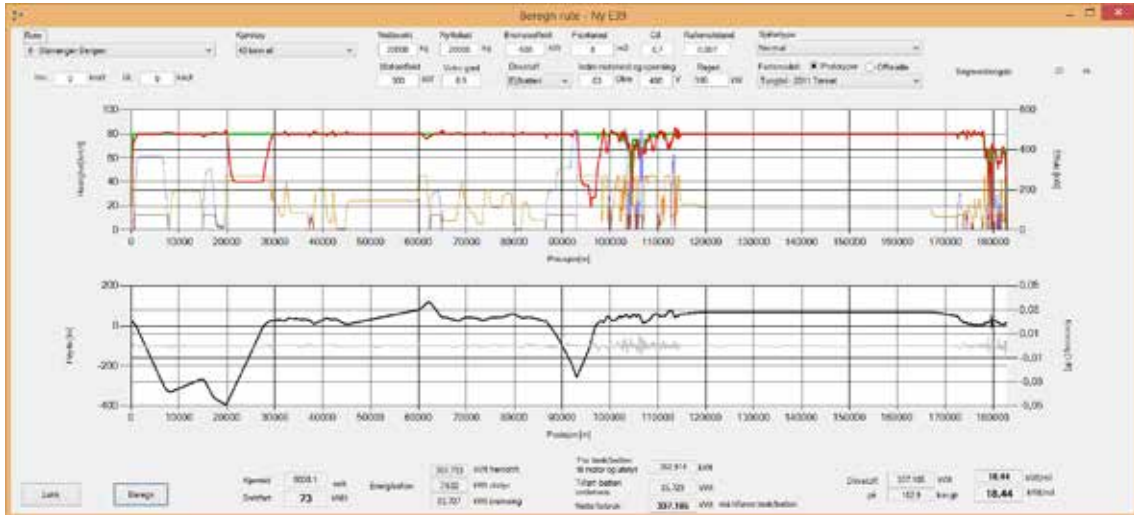

Figure 7 Electrified truck from Stavanger to Bergen. Larger print on page 29.

- Total forward work on wheels = 308 kWh (11 kWh more than with diesel, because of 2 tons)
- Total brake work on wheels = 84 kWh, of which 26 kWh was recovered
- Because of internal resistance and accessory power, 337 kWh available battery capacity is needed

This transport operation utilizes 100% of the battery capacity, which is not a realistic. If maximum 70% of the capacity is to be utilized, a 480-kWh battery pack is required.

### 3.3 Electrification with external power in ascents

There are two deep tunnels along the road. As a test, the software does not drain the battery during the ascents from the tunnels. This means that requested power is supplied from the outside at a rate of 300 kW, between 20 km and 30 km, and between 93 km and 98 km, a total length of 15 km done in 1259 seconds, or 0.35 hours.



Figure 8 Electrified truck with 15 km conductive power input. Larger print on page 30.

Figure 8 shows that by adding conductive power transfer of 300 kW along 15 km of road, the battery capacity requirement is reduced from 337 kWh to 226 kWh, i.e. a reduction of 111 kWh, or 33%. This means that 67% of the battery capacity is used. Note that in this example, almost all external power is transferred directly from the infrastructure to the engine, and is not passing through the battery. The reason the ascents are chosen, it is that this is the place where losses from internal resistance are biggest, and the speed is lowest. In this example, the internal battery losses are close to zero.

### 3.4 Electrification with power added on flat road

If instead, the same 15 km conductive stretch with 300 kW power is placed along the horizontal part of the route, things look a bit different. Between 125 km and 140 km, the wheel power requirement is about 102 kW, using 115 kW of outside power. Along this stretch the battery is also charged.

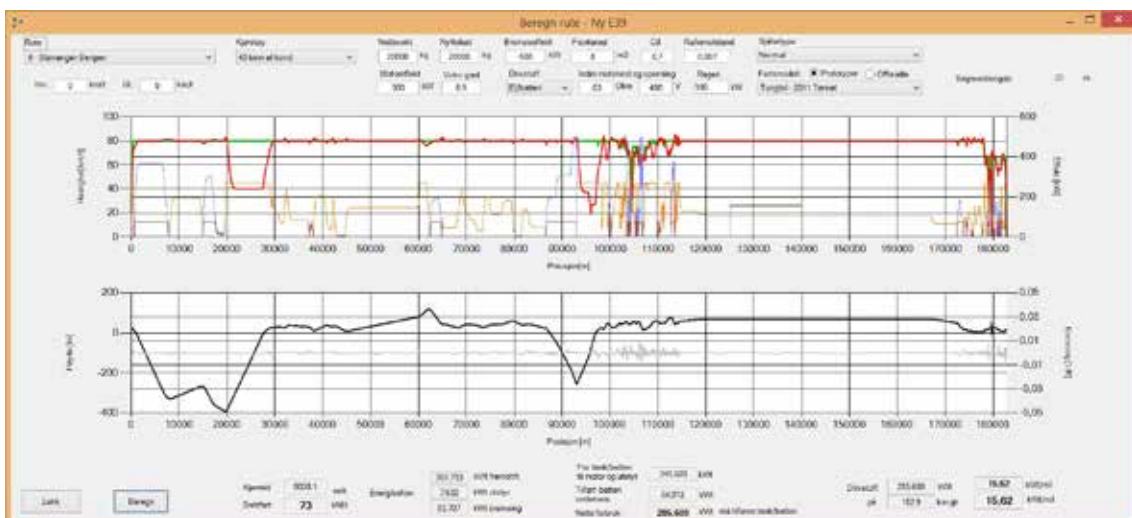

Figure 9 Dynamic on-road charging. Larger print on page 31.

The result is that required battery capacity is reduced from 337 to 286 kWh, a reduction of 51 kWh, or 15%. The computation log show that this stretch was passed in 676 seconds, or 0.188 hours. If there were no charging losses, the battery requirement should be reduced with  $300 \text{ kW} \cdot 0.188 \text{ h} = 56 \text{ kWh}$ . This means that with the defined battery, the charging loss on flat road is around 5 kWh, or 10% of the received energy.

### 3.5 Extended road electrification

A total of 337 kWh must be delivered from battery and charging equipment during the 2.5-hour trip, giving an average power consumption of 134 kW, seen from the battery.

With 300kW external power available and 10 % charging loss, a maximum of 270 kW is available for a vehicle during charging. If 33% of the route is electrified, an average of 90kW of useful power is available to the vehicle. The difference, an average of 44 kW during 2.5 hours, i.e. 110 kWh, must be stored onboard from the start, as a minimum. With maximum 70% utilization, a minimum battery capacity for this situation would be 160 kWh.

### 3.6 Conclusions from vehicle perspective

In the examples shown here, the optimal places for conductive power transfer are the tunnel ascents. The main reason is that low speed provides more time for energy transfer. Thus, also other steep ascents or sections with reduced speed limits could be suitable locations for charging infrastructure. The effect of reduced losses from internal battery resistance plays a minor role.

With a 15 km stretch (8% of the route) of 300 kW conductive power in the tunnel ascents, the battery requirements for a 42-ton truck between Stavanger and Bergen can be reduced with 33%. Because of the lowered speed, this corresponds to 14% of the travel time. A battery pack of 320 kWh should be sufficient.

If the conductive stretch is extended to cover 33% of the travel time, the battery size can be reduced to 160 kWh for the described route. The strategy for dynamic conductive power transfer is not considered, as the different proposed solutions are expected to have similar efficiency and power levels. In general, the results for dynamic inductive charging will also be similar, although the charging efficiency is expected to be lower than conductive solutions.

In this example, regenerative braking is limited to 100 kW, and contributes with almost 10% of the required energy. If maximum regenerative power is the same as the propulsion power, 16% energy saving is possible on this stretch, but only 12% between Kristiansand and Stavanger. Using a static model of the energy budget, Taljegård et al. (2017) estimated the regenerative potential to contribute as much as 20% of the total energy demand (on the wheels)<sup>1</sup>. Nonetheless, given that batteries are expensive, regeneration of energy is a welcome way of reducing the capacity requirements. Batteries are seldom

or never fully charged, so energy from braking periods are almost always stored. Since the biggest problem in electrified transport is getting enough energy into the batteries fast enough, there does not seem to be any need for or advantage from of bi-directional power flow (i.e. letting the vehicle deliver braking energy back to the grid) for the investigated road profile.

The dynamic energy model estimates that a 42-ton electrified truck described requires, on average, 1.8 kWh battery energy per km. A similar calculation for the 205 km route between Kristiansand and Stavanger gives 1.7 kWh/km. Reducing energy and battery requirements by improving the vehicles themselves is not an issue here, but it is worth noting that the Tesla Semi is recently introduced,

<sup>1</sup> Taljegård et al. (2017) Spatial and dynamic energy demand of the E39 highway – Implications on electrification options. Applied Energy (195) 681–692.

claiming a consumption as low as 1.2 kWh per km. If air drag is reduced to 0.35 as they claim, rolling resistance is lowered to 0.005, regenerative power is doubled and the route is flattened (which is unlikely), then this number is achievable according to this calculation method. Improving the vehicle can thus reduce requirements with as much as 0.5 kWh/km for this kind of transport. If these improvements can be made, the dynamic charging coverage can be reduced from 33% to 20% while keeping the same 160 kWh battery.

One should note that requirements calculated here are minimum, assuming that full charging power is always used, and that state of charge is not an issue. One should also note that a 50% increase in rolling resistance, which might happen during winter<sup>2</sup>, will increase the energy consumption with 20%.

If the truck is fully loaded, with a total weight of 50 tons instead of 42 tons, a 15% increase in consumption is expected. If this is combined with increased winter rolling resistance, a 38% increase is expected.

If winter conditions give lower battery temperatures, it could affect both available capacity, maximum charging power and lifetime of the batteries. For example, low temperatures can lead to lithium metal deposition on the electrode surface, especially at large battery currents. Thus heavy loading, either for traction (i.e. steep ascent) or charging will have significantly stronger impact on battery lifetime at low battery temperatures (Uddin et al., 2016)<sup>3</sup>. However, it is reasonable to assume that battery packs of this size and cost suitable for 50-ton trucks will have their own thermal management systems, so varying ambient temperatures should not have any significant influence on regular operation of such vehicles.

### 3.7 Vehicle battery savings

Adding charging options along the route reduces battery requirements and costs, but also vehicle weight and total energy consumption. Total cost will also be affected if charging increases or decreases the time spent that is not mandatory resting time. It is also possible that relying on high power charging during short stops will increase electricity cost<sup>4</sup>.

In appendix 1, a simple calculation is made to quantify the savings from reduced battery size. With the given transport, and battery properties as described, a 14% dynamic charging time coverage (which corresponds to the first example) will save 71' NOK per year, while a 33% coverage will save 169' NOK a year. 93% of these savings comes from reduced battery cost, while the rest comes from reduced energy consumption.

One should also note that if dynamic charging increases driver time and expenses, the savings will diminish fast. In the same way, if actual driver time can be reduced, this will increase the benefit.

<sup>2</sup> [http://www.tc.gc.ca/en/programs-policies/programs/documents/nrc\\_test\\_report-packed\\_snow\\_performance\\_eng.pdf](http://www.tc.gc.ca/en/programs-policies/programs/documents/nrc_test_report-packed_snow_performance_eng.pdf)

<sup>3</sup> K. Uddin et al., 2016. "Characterising Lithium-Ion Battery Degradation through the Identification and Tracking of Electrochemical Battery Model Parameters," in Batteries, Vol. 2, No. 2, Article 13, 17 pp.

<sup>4</sup> <https://www.mckinsey.com/business-functions/sustainability-and-resource-productivity/our-insights/how-battery-storage-can-help-charge-the-electric-vehicle-market>

## 4 Further developments of the energy calculation model

There are several ways to improve and extend the developed calculation method and software.

### 4.1 Accuracy and new applications

The accuracy of the calculation method is depending on the accuracy of the individual component models. In these examples, the individual component models are very simple, but they can be defined with any level of complexity.

We only have approximate information for drivetrains and components. More work must be done, especially on battery descriptions and rolling resistance, to create models that provides a more accurate representation of reality. It would also be useful to expand the route description used here with editable charging points and stretches. It would simplify this kind of calculations, and make it easier to compare configurations.

In addition, it would be interesting to add thermal properties to the components, to look at heating and cooling requirements. This may also be a step towards better accuracy in describing engine and battery behaviour. It could also be relevant to include load-dependent loss characteristics instead of assuming constant parameters or constant efficiency figures in the energy calculations. With better descriptions, it is possible to investigate in more detail the total effect of new battery types, energy management strategies and optimization of hybrid vehicles.

### 4.2 New components

One of the ambitions when designing the system, was to allow third-party developers and domain experts to define new components themselves, and test them with realistic loads. Examples could be improved battery chemistry, new fuels cells, cooling systems etc. More work is needed to define the interfaces that will make this possible.

### 4.3 Software environment

Currently, this system is built on top of TNext, and uses its mapping and route management functions to prepare the routes for calculation. But once done, and the route is saved to a JSON file or similar, the method is not relying on GIS functionality. It is therefore possible to create independent libraries for the calculations, and use them in other environments and software packages. One version of such a library is already created, adapted for use with NPRAs tools for cost/benefit analyses.

### 4.4 Emissions and total economy

Today the system also calculates CO<sub>2</sub> emissions, and can do basic NO<sub>x</sub> emission calculations based on "EMEP-EEA air pollutant emission inventory guidebook" (EMEP, EEA, 2016). This means that the system is useful for analysing the environmental and energy effects of various vehicle configurations from a technical standpoint. The next logical step, as this project demonstrates, is to look at the environmental and economic effects on a larger scale. However, such analyses involve many other factors and can be studied more conveniently in a separate environment. Software for such analyses exists, and it could be interesting to look at possible benefits of closer connections between these such systems.



## 5 Traffic volumes and energy demand on coastal highway E39

In this chapter, we determine the traffic volume of heavy vehicles, defined as vehicles over 12.5 meters. The traffic volumes will then be used for an estimation of the required electric energy demand along the same route. The main objective is therefore to: (1) Estimate the traffic volume on each road link for vehicles over 12.5 meters, and (2) estimate the energy demand for the different regions along E39 in MW/km.

The evaluation is based on the traffic volumes supplied by NVDB (National Road Database), traffic counts supplied by NPRA (Norwegian Public Roads Administration), and energy consumption calculations done by SINTEF. A description of the data sources used in this Memo is shown in Table 2.

**Table 2 Sources for evaluation of traffic volume**

Title	Source	Description
Traffic volume, average annual daily traffic (AADT)	NVDB/www.vegkart.no	For each road link, the number of vehicles passing on an average day is presented, based on observations, models or estimations. The number is the sum for both directions.
Share of heavy vehicles (vehicles over 5.6 meters)	NVDB/www.vegkart.no	For each road link, there is a share of heavy vehicles, based on observations, models or estimations.
Traffic counts	NPRA	Observed counts classified by length classes. Cut-off points are 5.6 m, 7.5 m, 12.5m and 16m.

### 5.1 Estimating traffic volume

First, available information is visualised as the number of cars per day. In the figure below, the X-axis provides the distance along the road, starting at the location closest to Kristiansand for which data are given. The distance is calculated using the route planner of Statens Vegvesen. For easier identification, city-names has been added to the plot.

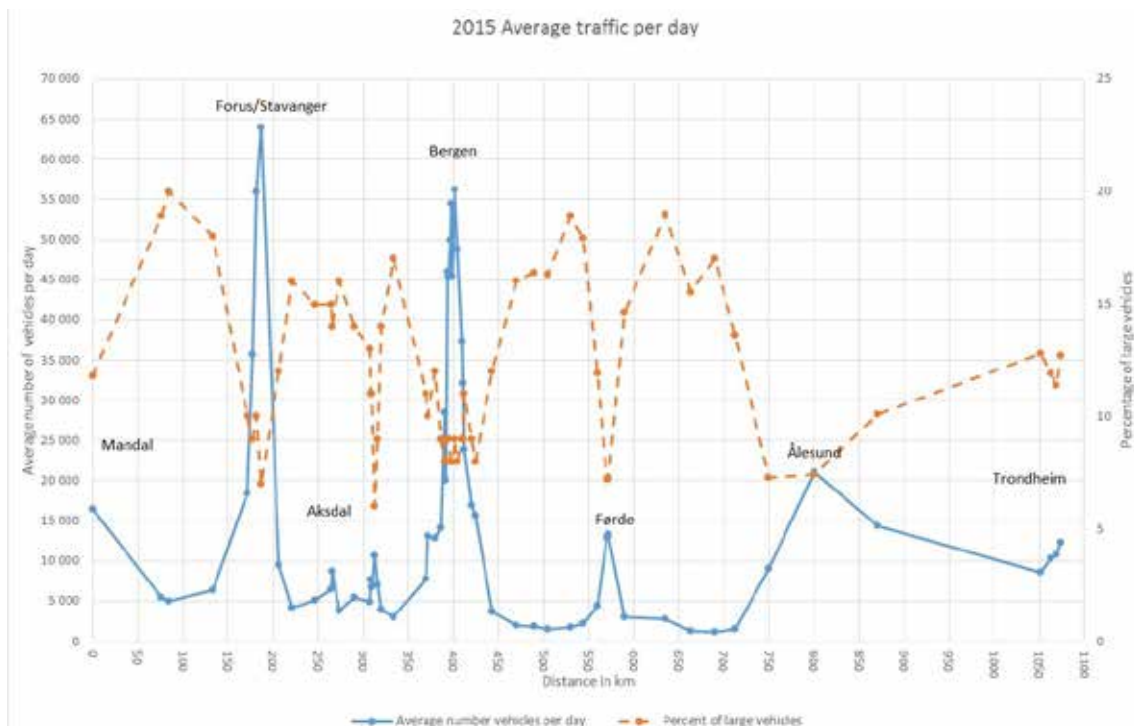

**Figure 10** Yearly average number of cars per day and location.

It is interesting to see that peak number of cars occurs around larger cities, while at the same time the percentage of trucks is comparatively low. This is especially pronounced at Forus, a commercial area between Sandnes and Stavanger, where a large number of offices and services are located. This implies that there is a large number of commuters in this area. It is likely that the same applies to other urban areas as well.

The number of trucks at each point is visualised in Figure 11. Even though the relative number of trucks is low compared to cars, we can identify clear peaks around cities. The number of trucks are about five times higher than at locations in-between larger urban areas.

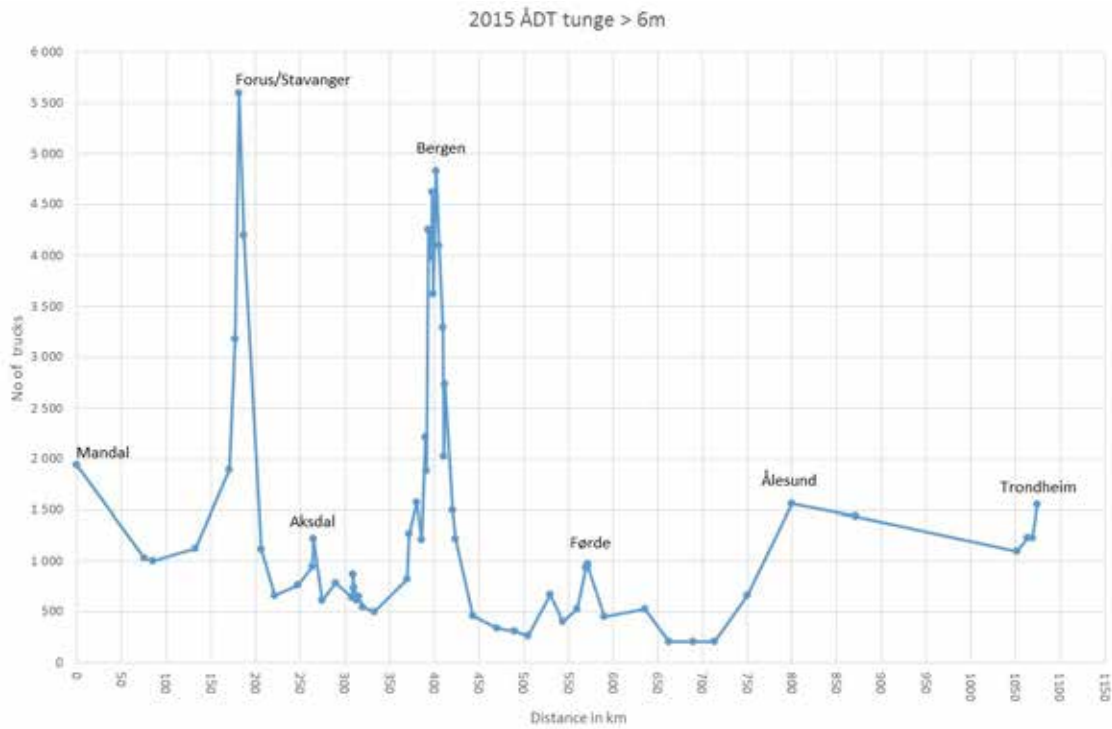

Figure 11 Average number of trucks (larger than 5,6 meters) per day for 2015.



Figure 12 AADT along E39. The height of each profile is determined by the AADT from NVDB.

The total AADT is also visualized directly in a map as shown in Figure 12. As can be seen from Figure 10 and Figure 12, the AADT is highest in and close to cities, such as Kristiansand, Stavanger, Bergen, Førde, Ørsta/Volda, Ålesund, Molde and Trondheim. Between these urban areas, the AADT is generally decreasing with distance. In the context of ELinGO, an important question is: How many of these vehicles are over 12.5 meters (and thereby a potential user of any kind of electric infrastructure including overhead lines), and how far do they travel. In a comparable study, Taljegård et al. (2017) found that approximately 12% of the vehicle kilometres driven on E39 is from heavy vehicles (including buses)<sup>5</sup>.

We estimate the number of vehicles over 12.5 meters travelling between cities by finding the minimum amount of vehicles detected at NPRAs traffic detection sites (TDS). Note that we have not considered the road sections between the TDSs in this project, and hence assume that the lowest observed number at the TDSs between each pair of urban areas is the actual number of vehicles over 12,5 meters traveling between the urban areas. For all urban areas, these values are shown in Table 3.

**Table 3 Observed daily count of vehicles longer than 12.5 meters between urban areas.**

Route	Observed number of vehicles >12,5 m
Trondheim–Molde	100
Molde–Ålesund	250
Ålesund–Volda	450
Volda–Førde	150
Førde–Bergen	150
Bergen–Stavanger	300
Stavanger–Kristiansand	600

## 5.2 Monthly and daily variations in the traffic volume

Variation occurs not only geographically, but also over time. To illustrate monthly variations, we collected data from the ferry connection between Mortavika and Årsvågen (Figure 13).

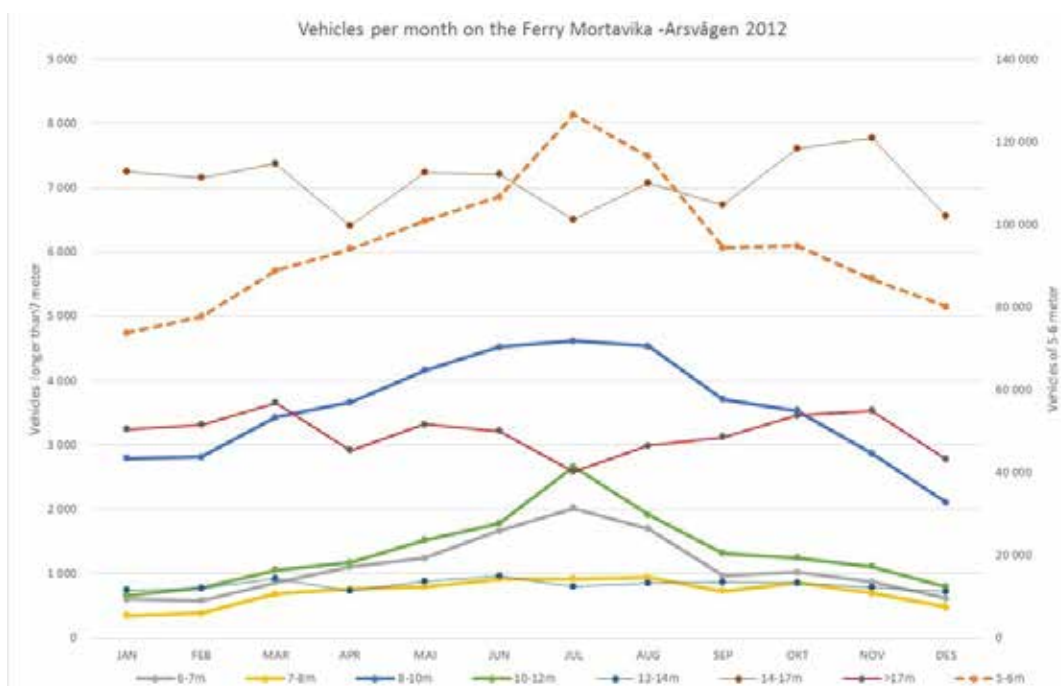

**Figure 13 Vehicles per month from the ferry connection between Mortavika and Årsvågen.**

<sup>5</sup> Taljegård et al. (2017) Spatial and dynamic energy demand of the E39 highway – Implications on electrification options. Applied Energy (195) 681–692.

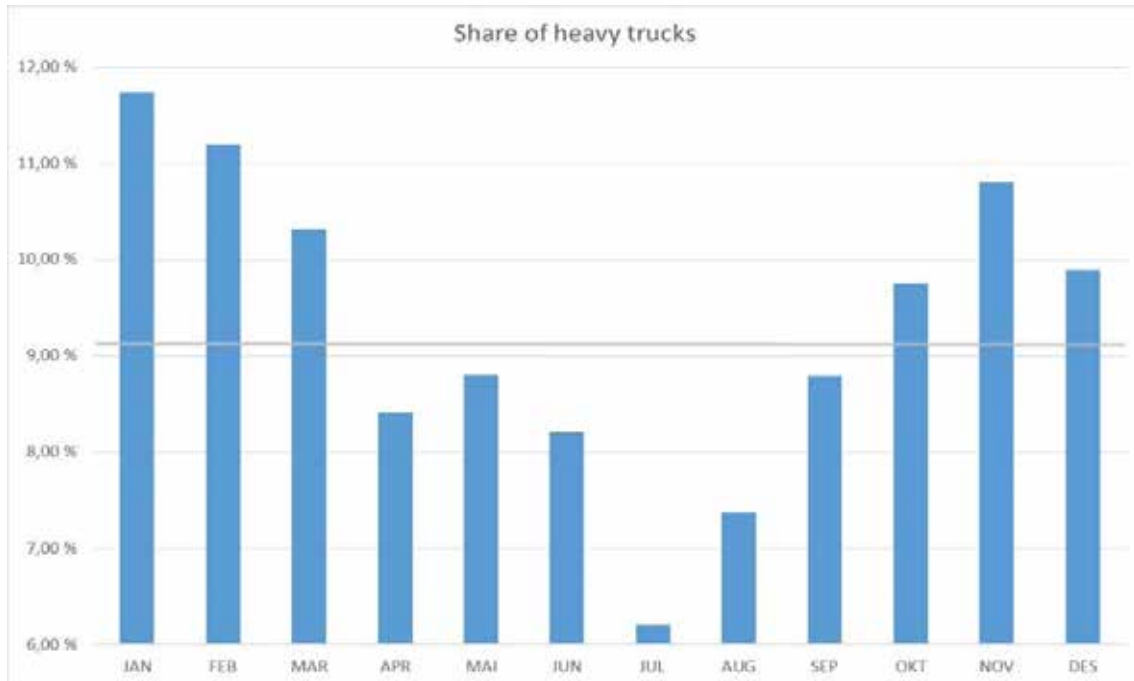

**Figure 14 Monthly share of heavy trucks on the ferry Mortavika–Arsvågen for 2012.**

As Figure 14 shows, the share of heavy vehicles varies during the year between 11,7% and 6,2%. An average value for the year is calculated as being about 9.1%.

Business traffic would be expected to decrease during the typical summer months (June, July, August). The numbers indicate that E39 might be one of the main North-South connections used by vacationers, which might result in peak numbers during the summer months. The results indicate that vehicles with lengths matching passenger cars (5–6m), camper (6–7m and 7–8m to a limited extend) and those representing passenger cars plus caravan (8–10m and 10–12m) have a significantly increase number during the typical periods of vacation. This contrasts with the number of heavy trucks represented by the even longer vehicles. For those, there is a decrease in December (during Christmas), in April (Easter), resulting from public holiday as well as several days of prohibited truck traffic, and July (summer vacation) visible.

Variations in traffic volume also occurs over shorter cycles (24 hrs/weekdays). To illustrate differences on such cycles, data representing the number of vehicles above 16m length was received for a location close to Boknafjorden. It is the traffic station ID 1100025, and the data for about two weeks in February 2015 is shown below in Figure 15.

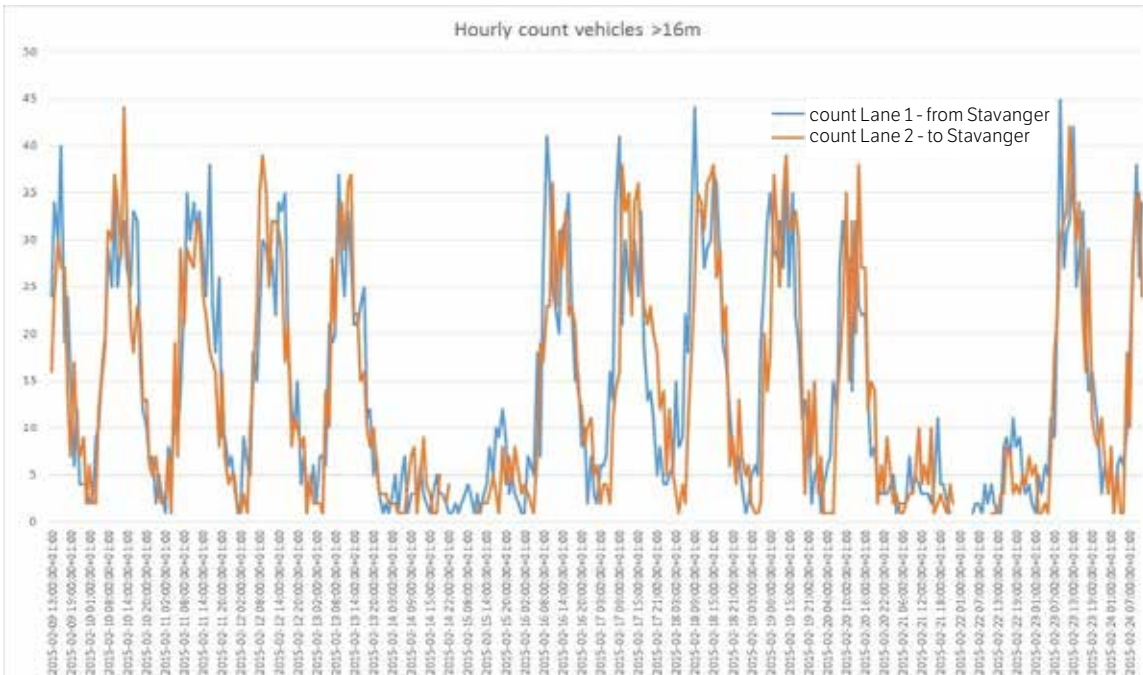

Figure 15 Hourly count of vehicles longer than 16 m at station 1100025 over two weeks.

There is a clear decrease in traffic during night time and over the weekends. To identify a kind of generic pattern, a zoom of 2 days is used. The green dotted line in the graph indicates a possible generic pattern (Figure 20). The general pattern is the increasing number of vehicles from about 5:00 in the morning till reaching a relatively constant value at about between 8:00 and 9:00. The number is then more or less stable till about 18:00, when it starts decreasing again and reaching the lower level at between 22:00 and 23:00 in the evening.

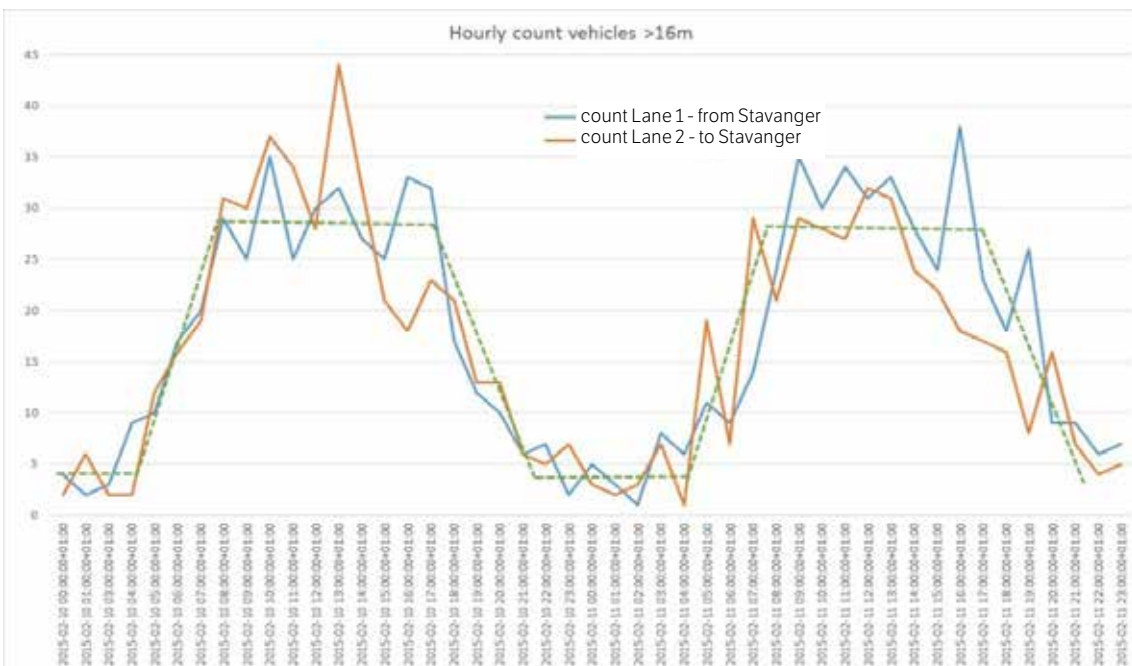

Figure 16 Hourly count of vehicles above 16m at station 1100025.

It should be kept in mind that a pattern as visible in Figure 16 is representing the current E39 including the currently necessary transfers via ferries.

### 5.3 Estimating the energy demand

Based on energy calculations for a 42-ton vehicle, the total power demand can be estimated, as shown in Table 4. The total power for each vehicle is calculated as seen from the battery, using the planned road segments along E39.

**Table 4 Total power demand in MWh per day for the 7 different areas defined here.**

Route	Length [km]	Energy [MWh/vehicle]	Vehicles per day	Energy demand [MWh/day]	Energy demand [MWh/day/km]
Trondheim– Molde	210	0.397	100	40	0.190
Molde– Spjelkavik(Ålesund)	71	0.132	250	33	0.465
Spjelkavik(Ålesund)– Volda	62	0.099	450	45	0.726
Volda– Førde	124	0.208	150	31	0.25
Førde– Bergen	156	0.294	150	44	0.282
Bergen– Stavanger	183	0.337	300	101	0.552
Stavanger– Kristiansand	205	0.354	600	212	1.034

### 5.4 Summary

The general interpretation of the results presented in the previous figures is that areas around cities are most likely dominated by shorter distance traffic/trucks, while long distance transport is the main transportation contributing to locations outside the city areas. In terms of dimensioning the electrification of E39 some questions should be evaluated:

- Whether the system shall consider long distance transport only for planning capacities and return of investment (=> kWh pricing).
- Whether short distance transport is expected to make use of charging possibilities on E39, where criteria such as NOK/kWh on E39 versus external charging might play a role.
- Whether long distance transport might combine necessary breaks with charging batteries outside the area of E39 (e.g. maybe for cost reasons).
- Whether the selected technology matches with that of other countries (in case of transport across borders).
- The daily pattern seen in some areas appears to be correlated with ferry departure times, but the remaining question might be if the pattern will be different in case of a ferry-free E39. It is expected that truck drivers try matching their mandatory rests with the availability of ferry transfers.
- Available data have one hour as the finest resolution. In order to evaluate possible aspects of truck convoys etc at a more detailed resolution, it is necessary to collect additional data.
- The estimated energy demand shown in this memo, reflects the current situation. However, with the growing demand for freight transport, the energy requirements is expected to increase in the coming years.

## 6 Grid load and capacity

For considering how the energy and power demand of electric road infrastructure will influence the power system, it is useful to consider the general structure of the Norwegian electricity grid as shown in Figure 21. This figure shows how a substation for supplying an electrified road section will usually be connected to the high voltage distribution grid. In Norway the voltage level for the high voltage distribution grid is typically 11 kV or 22 kV, with most overhead lines in rural areas being operated at about 22 kV. The high voltage distribution grid is usually based on a radial configuration with multiple feeders supplied from a transformer station with connection to a regional transmission grid.

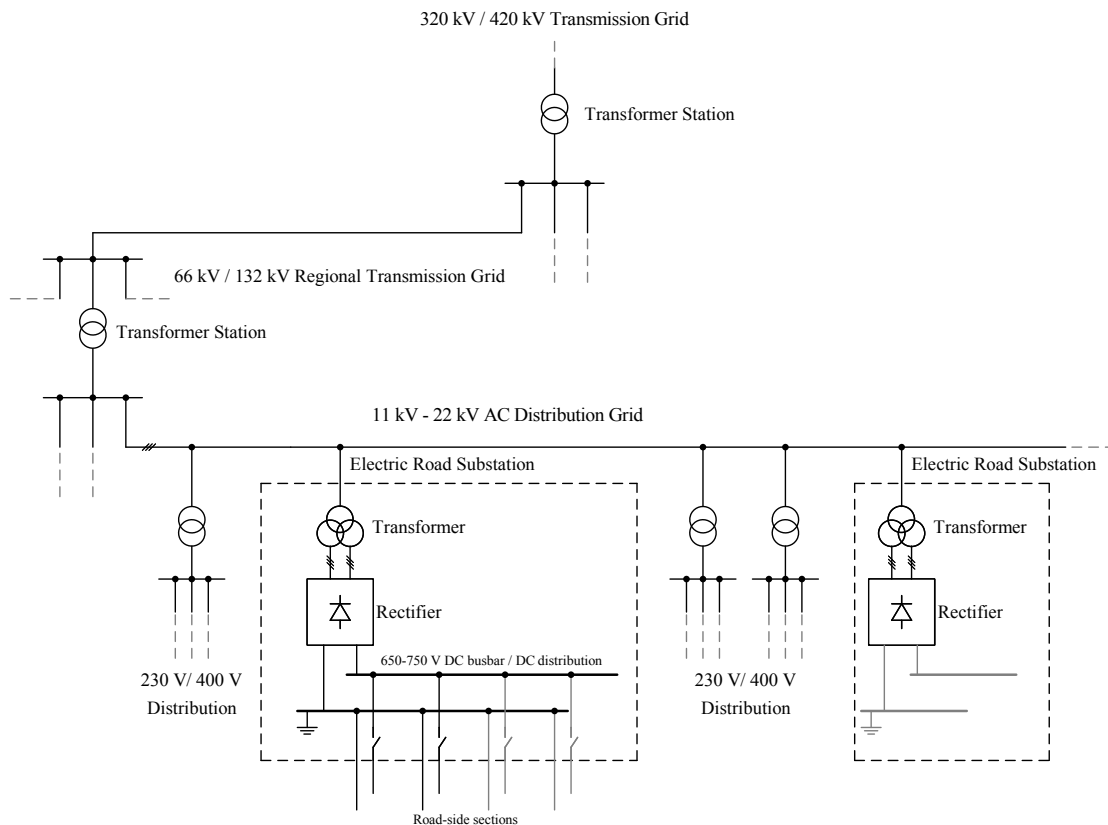

**Figure 17. General structure of the Norwegian power system.**

The general configuration of the power system implies that the substations for supplying any electric road infrastructure will usually have to be connected to a distribution line that is also supplying other loads, including multiple distribution transformers feeding the local low voltage distribution networks. Thus, there are generally three potential challenges that can imply additional costs for supplying power to the electric road substations:

- If there is no distribution line already existing along the road, the high voltage distribution system will have to be extended to the suitable connection point for the electric road substations.
- If the distribution feeder along a road section does not have enough capacity for connection of the required electric road substations, it will become necessary to upgrade or expand the existing distribution system.
- If the total load added to a distribution line, or to multiple distribution lines supplied by the same transformer station, by the electric road infrastructure causes the total load of a transformer station to exceed its power rating, the interface to the regional transmission system might have to be upgraded.

Considering the case studied in the ELinGO project, the E39 from Kristiansand via Vestlandet to Trondheim is generally passing through the coastal regions in the west part of Norway. This part of Norway has many hydropower stations, cities and villages, and generally a distribution grid system covering the rural areas between the cities. Along this 1.100 km long road 13 grid companies have been contacted within the project. There has been a good cooperation with most of the grid companies, and the majority has provided some data or information as basis for assessing the needs for investments in the power system that would result from a large-scale development of electric road infrastructure.

Grid companies in Norway are monopoly business, so their income and revenue are governed by strict rules from Norwegian energy authorities. All grid companies in Norway are required to have a power system plan for the next 20 years. The power system plan describes the existing power grid, the expected future transmission situation, and the grid improvements and investments planned to meet the future needs. In addition, these plans describe energy availability (GWh) and power capacity (MW) in the grid area. The power system plans should contribute to a socioeconomically rational development of the regional grid system based on input from energy suppliers and consumers. However, such power system plans have uncertainties in loads and cost estimates for necessary investments in the future 20 years. As expected, the uncertainties increase gradually with the time horizon of the estimates. Several projects can arise or be changed depending on the state of the markets, and society can change as time goes by, implying that the needs to be served by the grid can become different than assumed by the grid companies in the assessment of future grid capacity requirements. Thus, the needs for additional investments to handle loads from electrification of heavy vehicles should be considered within the context of the existing condition of the local high voltage distribution systems as well as with respect to already confirmed plans and anticipated developments that will influence the local load demands.

## 6.1 Simplified grid loads

The average numbers of trucks per day along the 1100 km of the E39 is shown in figure 11 (chapter 5.1). This traffic load shows a high number of trucks close to the city areas (manly Stavanger and Bergen, but also cities like Kristiansand, Ålesund and Trondheim). Based on a general assessment of the high voltage distribution system in Norway and the general experience of Lyse, the electric capacity of existing distribution feeders along the E39 can be assumed to be in the range 1,5 up to 4 MW/km in urban areas, and in the range 0,3-0,5 MW/km for more remote areas.

However, a general assessment of the capacity for supplying electric road substations from the high voltage distribution system must also take into account the impact of distributed loads on the voltage profile of the distribution feeders. Based on general information for typical high voltage distribution lines, Lyse has made a calculation of the voltage drop resulting from connection of a 1,4 MW electric road substation every 2 km of a distribution feeder dedicated only for the electric road system (with a 400 AL cable). The result for three different voltage levels are shown in Figure 24, where the X-axis shows the distance in km between connection points to the regional grid, and the Y-axis shows the voltage drop. The allowable voltage variations due to load changes over the day is typically limited to 4 %, which would directly imply the expected distance between connections to the regional transmission grid from the curves in Figure 22 if it should be assumed that the load will be very low during some hours of the day (typically during the night).



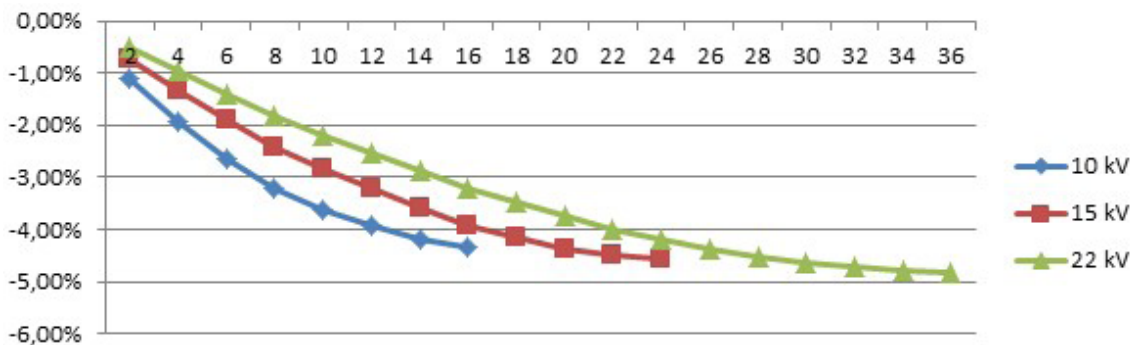

**Figure 18** Voltage drop related to distance in km.

This figure would apply to urban areas with full electrification of a road distance. In such cases it could be reasonable to assume that there will be a transformer station for connection to the regional transmission grid within about 10-20 km. However, in rural areas, it is expected that there will be longer distance between the connections to the regional grid due to lower load and longer radials with a combination of various loads in addition to the electric road substations. However, as discussed in the first parts of this document, it could be reasonable with only partial electrification of the road distances. Thus, a practical development of dynamic charging infrastructure would likely benefit from adapting to the local power system structure as well as to the local topography.

## 6.2 Cost estimates for grid investment (cost for grid companies)

For obtaining a preliminary estimate of required power system investment cost as a result from electrification of the E39, it has been assumed that the utility companies should be responsible for the local grid system along the road for feeding the charging system (overhead power lines and pantograph, electric system in the road surface, or other charging options). The grid companies will in any case be responsible for connecting the electric road system to the regional grid. The cost of the charging infrastructure, i.e. the overhead lines or the local low voltage distribution for the shorter sections of conductive or inductive elements integrated in the road have not been considered as part of the required power system investments. On this basis, the 13 contacted utility companies have been asked to provide cost estimates for the grid extensions or reinforcements expected for electrification of the E39, and the provided answers are summarized in Figure 23.

It should be noted that the estimated costs presented here are mainly calculated without considerations of uncertainty. Normally it should be added 40–50% extra cost due to the uncertainty in the expected load demand for the road electrification and due the fact that an electrification probably will happen maybe 10-15 years into the future. Thus, transport amount, transport solutions and other conditions can change over time, resulting in different energy and capacity needed for an electrified E39 than expected by the grid companies.

Grid company	Geographic area	Assumed capacity (MW/km)	Today status regional grid	Cost estimate in regional grid (MNOK)
Agder Energi Nett	Øst- and Vest-Agder	1,4 from Kr.sand to 0,4 at Vigeland; approx 54 km. Thereafter 0,4 until Bue in Rogaland.	Vurdert at 3 transformatorstasjoner vil ha for liten kapasitet.	100
Dalane Energi	Bjerkreim, Eigersund, Lund og Sokndal municipality	Approx 0,4-0,5 MW/km new road		48
Klepp Energi	Klepp municipality			
Jæren Energi	Hå municipality			
Lyse Elnett	Stavanger, Sandnes, Sola, Randaberg, Finnøy, Rennesøy, Strand, Time, Gjesdal, Hjelmeland og Kvitsøy.	0,4 from Bue increasing to 4,1 MW/km by Hinna, reducing to 1,0 MW/km by Harestad. 2,0 trough the planned tunnel Rogfløst		100-200
Haugaland Kraft Nett	Haugesund, Karmøy, Vindafjord, Tysvær, Bokn, Utsira, Sveio, Stord og Sauda.	Approx 0,4-0,5 MW/km new road		243
Finjar Kraftlag	Finjar	Approx 0,4-0,5 MW/km new road		
Tysnes Kraftlag	Tysnes	Approx 0,4-0,5 MW/km new road		
BKK Nett	Regional grid operator between Hardangerfjorden and Sognefjorden	Approx 0,4-0,5 MW/km new road		100-150
Sunnfjord Energi Nett	7 municipalities from Solund i west to Stardalen in Jølster in east.	Approx 0,4-0,5 MW/km new road		
SFE Nett	Gloppen, Eid, Vågsøy, Bremanger, Flora, Askvoll og Selje.	Approx 0,4-0,5 MW/km new road	Lagt til grunn spenningsoppgradering i deler av	107
Mørenett	Ålesund, Giske Sula, Ulstein, Hareid, Herøy, Sande, Vanylven, Ørsta Volda, Hornindal og Norddal.	Approx 0,4-0,5 MW/km new road		
Istad Nett	Aukra, Eide, Fræna, Gjemnes, Midsund og Molde	Approx 0,4-0,5 MW/km new road		45-125
Neas Nett	Nordmøre	Approx 0,4-0,5 MW/km new road		
Orkdal Energinett	Orkdal	Approx 0,4-0,5 MW/km new road		20
TrønderEnergi Nett	Sør-Trøndelag	Approx 0,4-0,5 MW/km new road		22
Hemne Nett	Hemne municipality			
<b>SUM</b>			<b>Min</b>	<b>650</b>
			<b>Max</b>	<b>800</b>

**Figure 19 The regional grid investments excluded contingency**

It should also be remarked that the different grid companies have used limited time on the cost calculations presented in Figure 23 due to the fact of no payment could be provided for the work required to provide the estimations. The utility companies could deliver a more detailed work if specific analysis could be agreed and the cost of the work required for providing relevant analysis of the required grid reinforcements and corresponding investment costs on basis of local conditions could be compensated. In general, Lyse considers that a contingency of about 40–50% should be considered on the costs summarized in Figure 23. Thus, a total cost for regional grid investments are expected to be in the range of 900–1200 mill NOK.

## A Vehicle economy using electrified road

See separate Excel spreadsheet (below).

Electric trucks for longer distances are entering the market. They carry expensive battery packages, which can be reduced if charging more frequently. The following calculation looks at the saving potential for a vehicle using dynamic charging.

Antar at elektrisk kjøretøy ved valgfri batterikapasitet er tilgjengelig					
Rute	Lengde[km]	183	Besparelser av lading i fart		
Arbeidsdag	Kjørelengde (70 km/t i 8 timer) [km]	560	Redusert vekt [kg]	1 915	
			Redusert pris [kr]	638 278	
Batteri	kg/kWt	6	Pr tur	Forbruksreduksjon fra vekt[kr]	12
	Kr/kWt	2 000		Batt.utgiftsreduksjon[kr]	156
	Levetid [km] (5 års levetid)	750 000		Tidskost dynamisk lading	0
				Tidskost stasjonær lading	-424
Energipris	[kr/kWt]	1		Kost.reduksjon dynamisk [kr/tur]	168
				Kost.reduksjon stasjonær [kr/tur]	-256
Bil	Faste kostnader bil og sjåfør [kr/t]	570			
	Energiforbruk [kWt/km]	1,84			
	Forbruksendring pr tonn [kWt/km/tonn]	0,035			
	Lading virkn.grad	0,9	Pr dag	Dynamisk lading	514
	Forbruk [kWt]	336,72		Stasjonær lading	-785
	Maks batteriutnyttelse	0,7			
	Minimum batteri uten lading [kWt]	481	Pr år	driftsdager pr år	
				Kost.red. med dynamisk lading	169 657
Lading i fart	Effekt [kW]	300		Kost.red. med stasjonær lading	-258 973
	Fart under lading(km/t)	73			
	Fart uten lading [km/t]	73			
	Strekninglengde[km]	60,4			
	Ladetid [t]	0,83			
	Ladetid [sek]	2979			
	Energi overført [kWt]	223			
	Tidskostnad pr lading [kr]	0			
Stasjonær lading	Effekt[kW]	300			
	Ladetid [t]	0,74			
	Tidskostnad pr lading [kr]	424			

Figure 20 Estimates of costs with stationary and dynamic charging



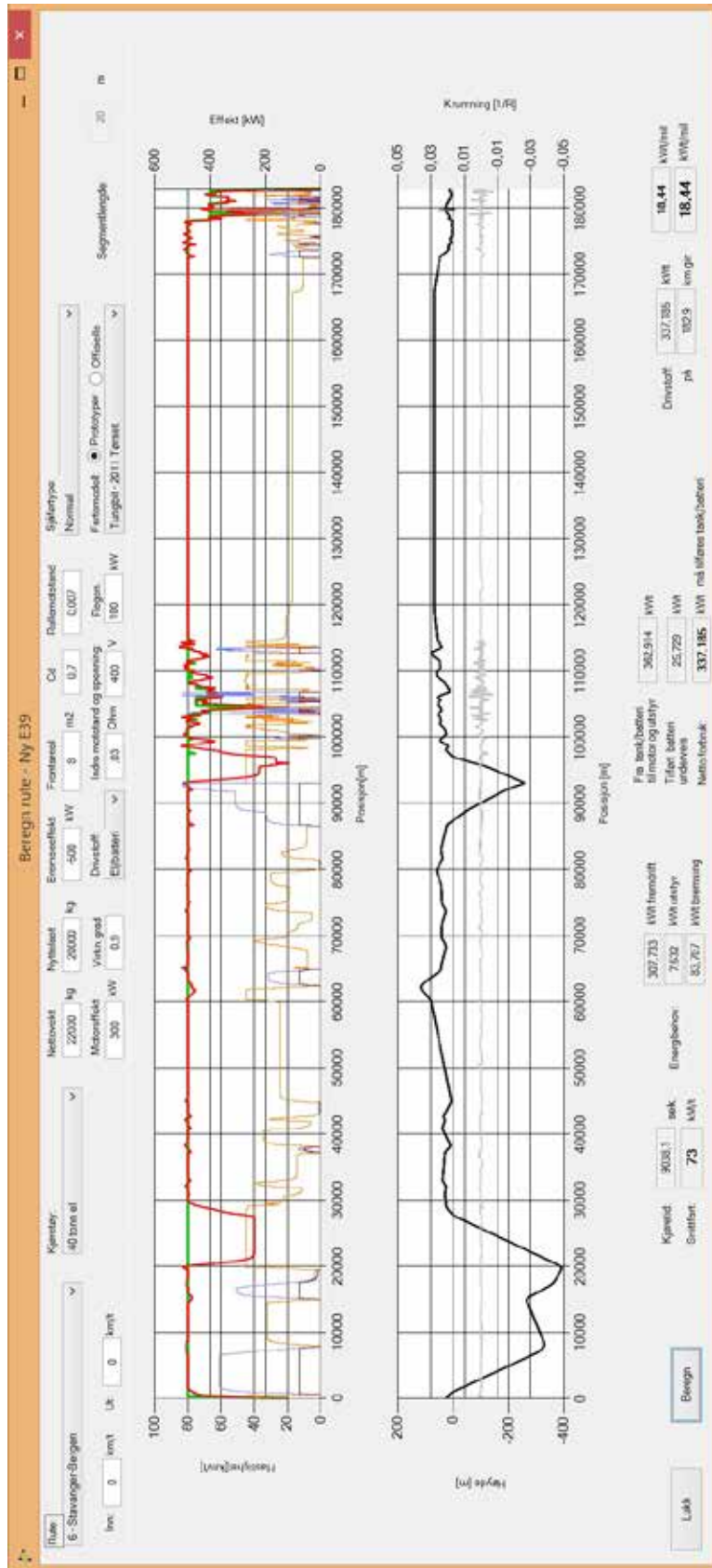

Figure 7 Electrified truck from Stavanger to Bergen



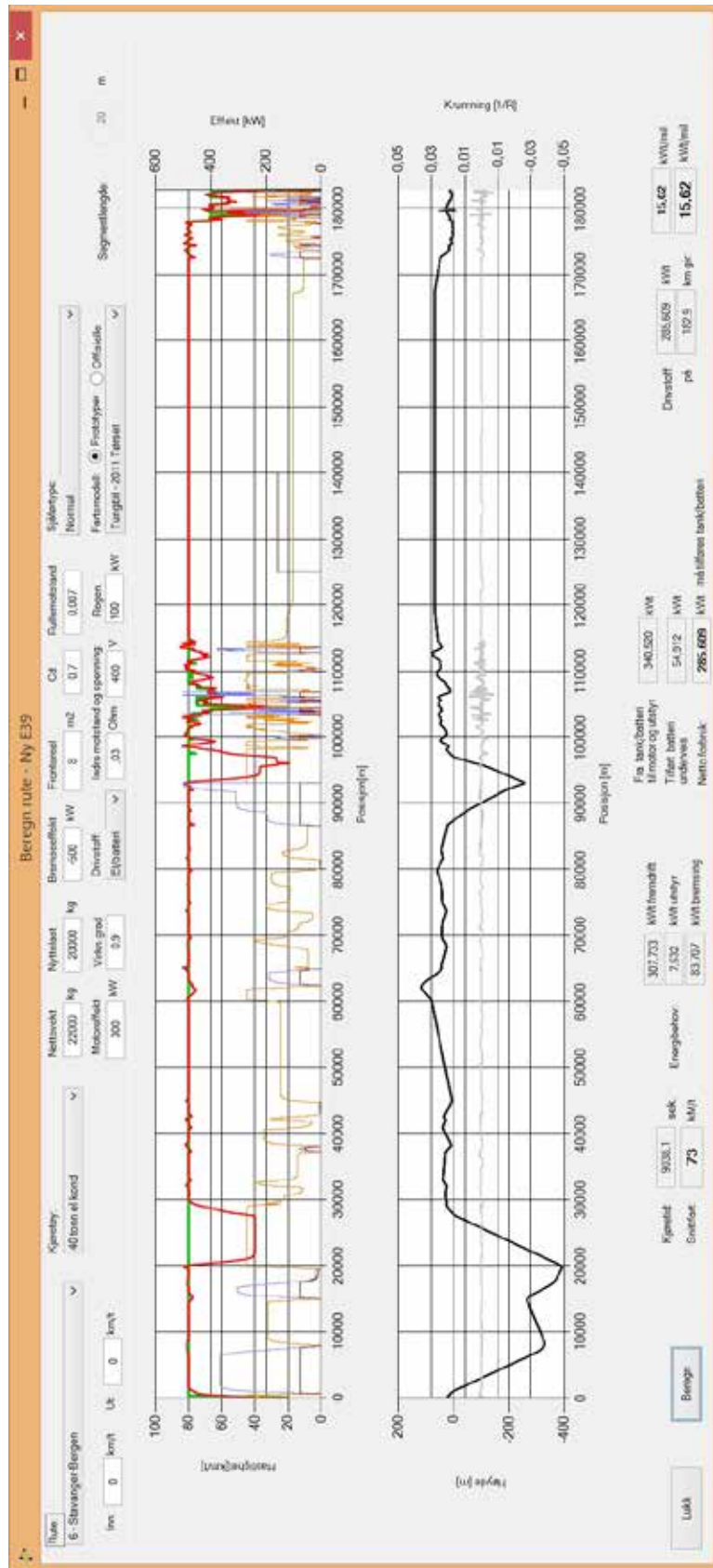

Figure 9 Dynamic on-road charging.



With funding from  
The Research Council of Norway