



SINTEF



## Report

### Industry practices for sharing information in the Norwegian fisheries supply chains

**Authors:**

Andrea Viken Strand, Maitri Thakur

**Report No.:**

OC2022 A-024 - Unrestricted

**Client**

Research Council of Norway

# Report

## Industry practices for sharing information in the Norwegian fisheries supply chains

**KEYWORDS:**Traceability  
Fisheries supply chain  
Data capture  
Information sharing  
Sustainability  
Norway**VERSION**

2.0

**DATE**

2022-02-24

**AUTHORS**

Andrea Viken Strand, Maitri Thakur

**CLIENT(S)**

Research Council of Norway / 294662

**CLIENT'S REF.**

Coolfish

**PROJECT NO.**

302004738

**NUMBER OF  
PAGES/APPENDICES:**

26

**ABSTRACT**

Sustainability and traceability of food products have received increased attention due to food safety, consumer demand on knowledge of the origin of their food and reducing food fraud. In recent years, traceability systems have been used to document and share sustainability information in food supply chains. This paper reviews the current methods of data capture and information sharing practices in the Norwegian fisheries supply chain from catch to consumption. Most Norwegian fishing vessels capture detailed data on the catch and quality of fish electronically. This information is automatically reported to the authorities while most information regarding the quality and sustainability is not communicated further down the supply chain. Significant data gaps include information on fuel and energy consumption, as well as detailed data on the transport routes and modes used. Increasing information sharing could potentially improve supply chain decision making and in-turn have an impact on producing sustainable high-quality fish products.

**PREPARED BY**

Andrea Viken Strand

## SIGNATURE

  
Andrea Viken Strand (Feb 28, 2022 09:13 GMT+1)**CONTROLLED BY**

Cecilia Gabriellii

## SIGNATURE

  
Cecilia Gabriellii (Feb 28, 2022 09:21 GMT+1)**APPROVED BY**

Kristina Norne Widell

## SIGNATURE

  
Kristina N. Widell (Feb 28, 2022 09:33 GMT+1)**REPORT NR.**

OC2022 A-024

**ISBN**

978-82-7174-433-5

**CLASSIFICATION**

Unrestricted

**CLASSIFICATION THIS PAGE**

Unrestricted

# Document history

---

VERSION	DATE	VERSIONS DESCRIPTION
1.0	2022-02-01	Draft sent to Quality Control
2.0	2022-02-24	Final report

---

# Table of contents

<b>1</b>	<b>Introduction .....</b>	<b>4</b>
<b>2</b>	<b>Aim and Scope .....</b>	<b>4</b>
<b>3</b>	<b>Methods .....</b>	<b>5</b>
3.1	Data sources.....	5
3.2	Modelling and visualisation .....	5
<b>4</b>	<b>Main findings .....</b>	<b>6</b>
4.1	The Norwegian supply chain of whitefish and pelagic fish.....	6
4.2	Overview of the information flow in Norwegian Fisheries.....	7
4.2.1	Catch operation .....	9
4.2.2	Landing .....	11
4.2.3	Processing.....	14
4.2.4	Transport .....	17
4.2.5	Retail.....	17
4.3	Certificates and standards for sustainability and traceability of wild caught fish.....	18
4.4	Regulations on seafood traceability .....	19
4.5	Information exchange practices in the fisheries supply chain.....	19
4.6	Information gaps – transparency, traceability, and sustainability .....	20
4.7	Stakeholder perspectives.....	20
4.8	Novel technologies and traceability examples in the fisheries industry .....	21
<b>5</b>	<b>Conclusion and further work .....</b>	<b>21</b>
<b>6</b>	<b>Bibliography.....</b>	<b>23</b>
<b>7</b>	<b>Appendix.....</b>	<b>25</b>
7.1	Interview guide .....	25
7.2	Information provided by the Norwegian Fishermen's Sales Organizations .....	26
7.3	Example of the eCatch software.....	27

## 1 Introduction

Only a fraction of the information about the catch, processing, and transport of seafood products in Norway is being transferred to other partners across the supply chain. Consumers are becoming more aware about the social and environmental impacts of the food they consume, and demand more information about the sustainability, origin, and processing of their seafood products (Norwegian Seafood Council, 2021b). Food traceability systems play a key role in storing, sharing, and communicating information about food products in a supply chain.

Several definitions of the concept of traceability of food products exist, and the most common definition is "the ability to trace". Olsen and Borit (2013) defined traceability as "the ability to access any or all information relating to that which is under consideration, throughout its entire life cycle, by means of recorded identification". This includes the origin of the product, all raw materials and ingredients, the processing of the product as well as when and where it took place. As defined by Olsen and Borit (2013), information flows in both directions of the supply chain, and not only downstream. As well as knowing the origin of a product, traceability also includes information about where the product is going. Full supply chain traceability consists of both internal and chain traceability where internal traceability is the system of tracking a product within a company, while chain traceability is the exchange of data and information between companies and actors throughout the supply chain (Olsen et al., 2019).

In the global fisheries industry, traceability and transparency are important measures to reduce illegal, unreported and unregulated (IUU) fishing. The Guardian found in a global study that 40% of all seafood products were mislabelled either by human error or fraud (Leahy, 2021). It is estimated that food fraud has a cost of around 30 billion Euros every year (European Commission, 2018).

Traceability in food supply chains is motivated by several drivers including food safety, legal and market requirements and quality verifications (Wang and Li, 2006). Food traceability systems can reduce waste streams by gaining more knowledge and optimizing the production (Wang and Li, 2006, Moe, 1998). For the producers, traceability systems could potentially reduce costs and labour related to information exchange and data capture by implementing digital systems (Olsen and Borit, 2013). Increasing the granularity of the traceability will increase costs, but also the benefits (Karlsen et al., 2012). Data and information exchange over the supply chain between fishing vessels and processors could optimize the production and improve the catch process (Thakur and Gunnlaugsson, 2018). Both fishing vessels and processors capture and store great amount of data electronically, but the information exchange between these operators are for the moment limited.

## 2 Aim and Scope

The aim of this report is to review current methods of data capture and storage technologies in selected fisheries supply chains in Norway to identify both technical and non-technical challenges for information exchange. The report focuses on the supply chain of whitefish and pelagic fish in Norway, from catch to retail. Fish products going to other types of products such as Omega-3 oils or fish feed have not been included. The report focuses mostly on traceability data, e.g., information on time and place of various stages in the supply chain, as well as specifications on species and amount of product (catch, processed product etc.). Data on quality, temperature, preservation methods, environmental data have been included where it has been deemed relevant. The report also identifies the current gaps in data capture and information exchange, and analyses how these gaps can be bridged.

### 3 Methods

#### 3.1 Data sources

This report is based on relevant existing literature in the field of traceability within the fisheries industry in Norway. The search strings included: 'whitefish', 'pelagic', 'fisheries', 'Norway', 'data capture', 'data collection', 'data storage', 'eCatch', 'Inova', 'Marel', 'processing', 'traceability', 'information exchange', 'information sharing' and 'supply chain transparency'. Relevant articles were selected and included in the review. Most articles dated back to before 2018 and even back to 2012. In addition to existing literature, company interviews were conducted to obtain updated information about the data capture and information sharing practices in the catching and landing stages in the fisheries supply chain. The interview guide can be found in Appendix 7.1. The information about processing and distribution including transport and retail of seafood products were mostly based on literature findings and current regulations.

The following actors were interviewed in this study:

- A fishing company using deep-sea trawlers with on-board handling of the fish
- Two Norwegian Fishermen's Sales Organizations with one for pelagic fish and one for whitefish

#### 3.2 Modelling and visualisation

Visualisation of the information and material flows in the supply chain have been made using a simplified version of the Material and Information Flow Modelling Technique (MIFMT) methodology developed by Islam et al. (2021). This system allows for both the information and material flows to be visualised in the same diagram. Figure 1 presents a generic example of a food traceability system with one food business operator. This diagram consists of several layers, where the top layer represents every food business operator in the supply chain. The flows between each food business operator are therefore external traceability flows. The lower levels consist of the steps of the supply chain within each food business operator, i.e., the internal traceability.

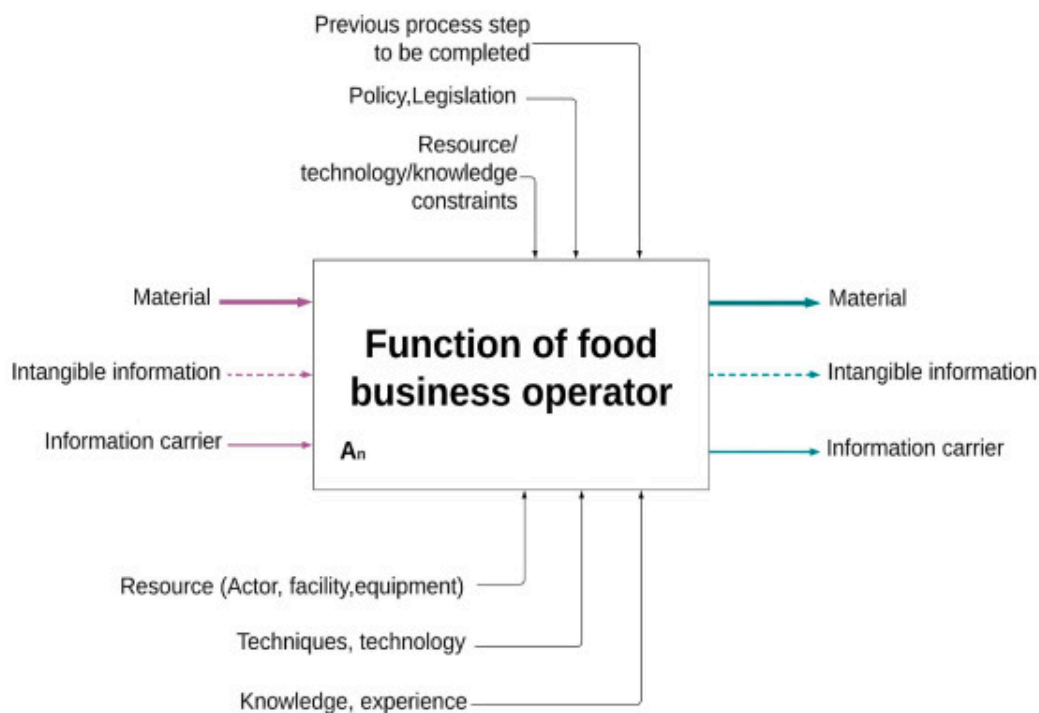

**Figure 1:** Representation of the MIFMT diagram for a generic food traceability system. Modified from Islam et al. (2021).

The MIFMT visualisation consists of:

- A function box: this can be a food business operator in the 0-layer of the diagram. In lower layers the function box can represent a task, a process, an activity etc. The number of function boxes in the 0-layer equals the number of food business operators in the supply chain
- Inputs: the input can represent material, intangible information (information that is oral or not necessarily linked to traceable unit), information carrier (information that is linked to a traceable unit such as a QR code, tag, label, barcode etc.).
- Outputs: same as the input. One output will also act as a control of the next step in the chain.
- Control: the control element represents a policy or legislation, or resource constraints.
- Mechanism: a mechanism represents resources (actors, humans, equipment etc.), technologies and knowledge.
- Logical connectors: AND, OR, Exclusive OR (XOR) presented in Figure 2.

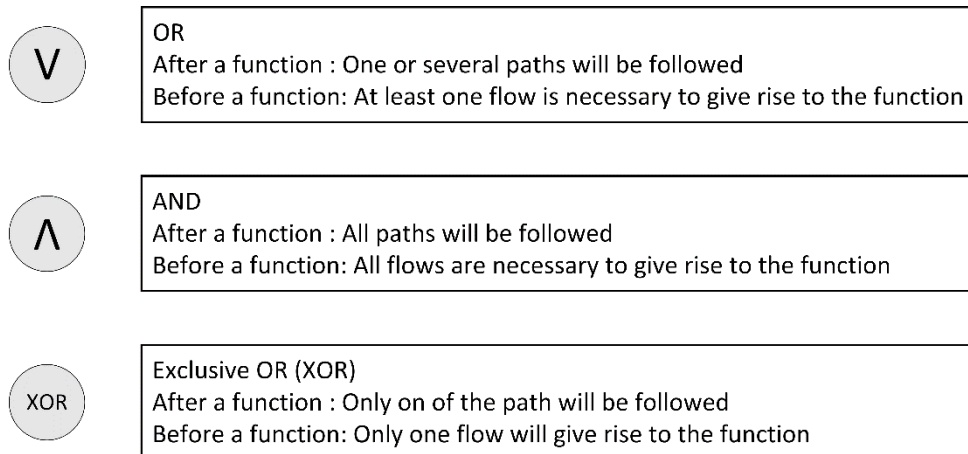

**Figure 2:** Logical connectors elements.

A simplified version of this diagram has been used to represent the information flows in the selected seafood supply chains. The input and output of material, intangible information, and information carriers, as well as the control elements (rules and legislation), have been included. These have been deemed the most relevant elements to include when analysing the information flows in the fisheries. All other elements in the MIFMT have been excluded in this study.

## 4 Main findings

### 4.1 The Norwegian supply chain of whitefish and pelagic fish

The supply chains of whitefish and pelagic fish were analysed from catch to retail. Catch volumes of whitefish including cod, saithe, and haddock amount to 654 431 tonnes in 2020 of which 289 292 tonnes were exported to a value of 11.93 billion NOK (Norwegian Seafood Council, 2021a, The Directorate of Fisheries, 2020). Most cod are exported in salted, dried, and frozen forms which have a lower value (Trondsen, 2012).

Catch volumes of pelagic fish, including herring, mackerel, capelin, sprat, and others, were 1 441 799 tonnes in 2020, of which 516 935 tonnes were exported to a value of 6.77 billion NOK. Pelagic fish is either consumed directly or sold as a raw material ingredient to fish feed production. Only 44% of the rest raw materials of white fish are currently being utilized, where as 100% of the rest raw materials of pelagic fish are being utilized (Hjellnes et al., 2020).

Figure 3 Shows the supply chain investigated in this report and includes the *Catch operation*, including the catch and on-board handling of the fish, the *Landing* of fish, *Processing*, *Transport* and *Retail* of fish to consumers.

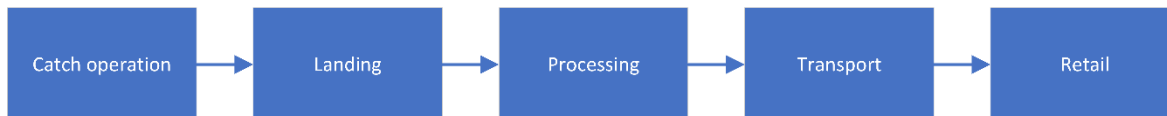
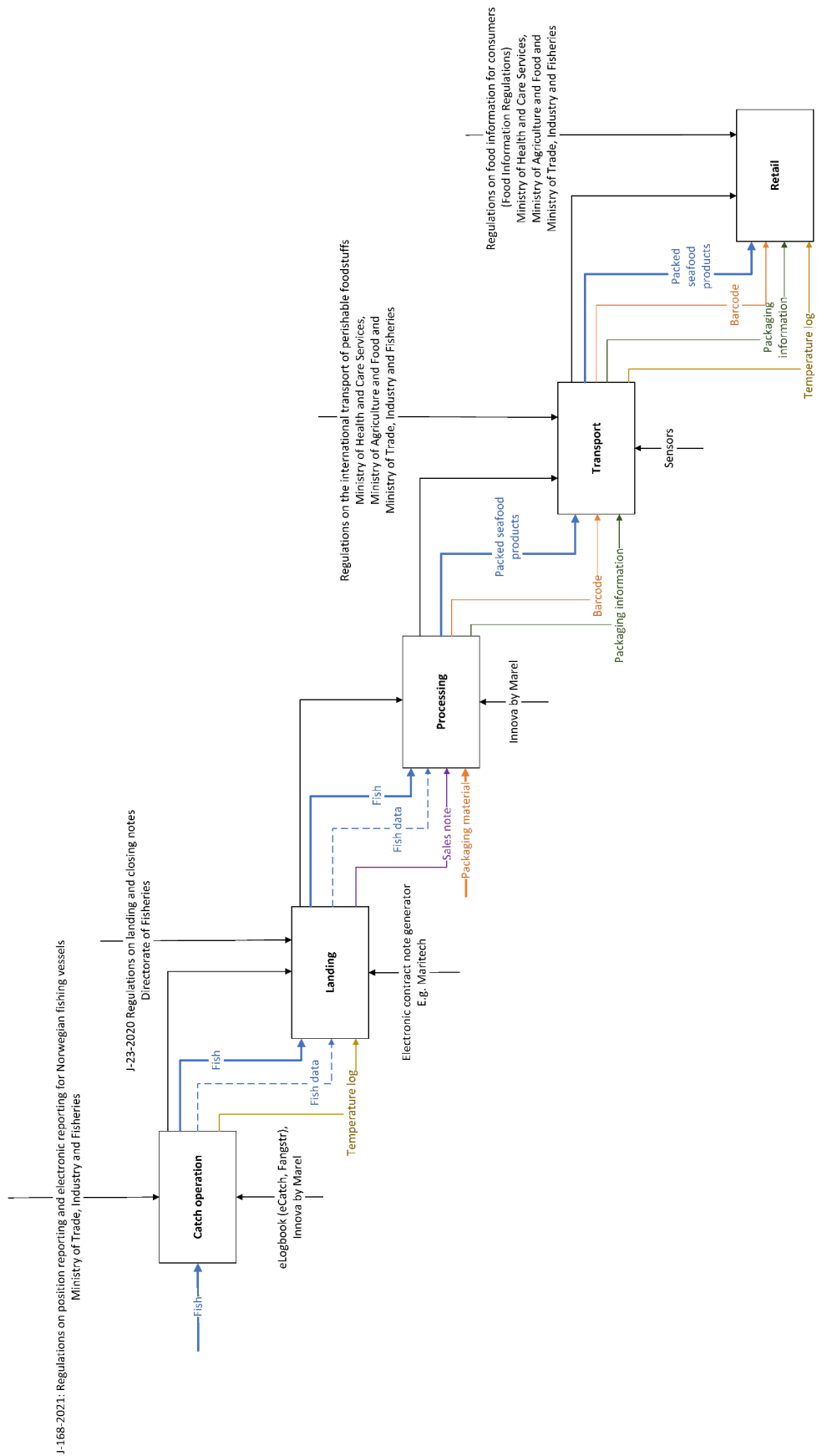

**Figure 3:** Fisheries supply chain from catch to retail.

## 4.2 Overview of the information flow in Norwegian Fisheries

Figure 4 shows the information and material flow of the Norwegian Fishery supply chain from catch to retail. The functions *Catch operation*, *Landing* and *Processing* are further investigated into sub-functions, presented in Figure 5-7. The *Catch operation* includes all activities taking place on the vessel; catching of the fish, sorting, weighting, on-board handling and quality inspection, storage and reporting to the Directorate of Fisheries. The *Landing* of the fish includes the sale of the fish from the vessel to the processing plant or export of the fish. The Norwegian Fishermen's Sales Organization has the responsibility to execute this authority on behalf of the Norwegian government and collaborates closely with The Norwegian Directorate of Fisheries which is an organization owned by the Norwegian fishing companies. After the fish is landed it goes to *Processing*, which includes quality inspection of the fish and processing into fillets and rest raw materials ready for transport to retailers. The functions *Transport* and *Retail* do not have any sub-functions in this report. *Transport* includes the transportation from *Processing* to *Retail*, while *Retail* includes the phase of the seafood being sold to consumers.





**Figure 4:** Information and material flow in Norwegian fisheries supply chain.

#### 4.2.1 Catch operation

The *Catch operation* is presented in detail in Figure 5 and includes the sub-functions *Catch, Sorting, weighting, quality inspection and on-board-handling, Storage on vessel, and Report Catch to Directorate of Fisheries*. The fish caught is then delivered to *Landing*.

All vessels above 15 meters are required to track their routes with Vessel Monitoring System (VMS) every 10 minutes, and report on their catch operation and where they are landing the catch with an Electronic Recording and reporting System (ERS) to The Directorate of Fisheries (The Directorate of Fisheries, 2021b). By July 2022 this regulation will also apply to all vessels above 11m. Reporting from the catching operation to the Directorate of Fisheries includes DEP (Departure Report), DCA (Detailed Catch and Activity) and POR (Port Report). DEP contain information on the vessel and when and where it departed from, DCA contains detailed information on the catch and POP contain information on when and where the fish is landed.

Many Norwegian vessels use eCatch as their ERS software. The system allows for registering the date and time as well as geographic coordinates for start and stop of the catch (Merrifield et al., 2019). Fishing gear and specification of the gear are recorded, and any problems related to the catch can be registered in the application. The total weight of the catch, the species caught and weight per species are also recorded in the eCatch system. eCatch is currently changing name to Fangstr and offers the service Fangstr VMS that reports positioning data as well as catch report (DEP, DCA and POR). The Fangstr software is developed to be as automatic as possible. eCatch/Fangstr also allows for strategic planning of the catch, by giving insights about where to catch and when, based on catch statistics recorded in the software.

Some vessels also have on-board handling of the fish, that can include slaughtering and bleeding of fish, sorting by size and species, freezing and palletizing. The software, Innova by Marel, is used by the vessel interviewed in this study, to store data (quality, species, sizes) about the fish. The software automatically updates and corrects the data recorded with the eCatch system. The relevant data recorded at each step in the *Catch operation* is presented in Table 1.

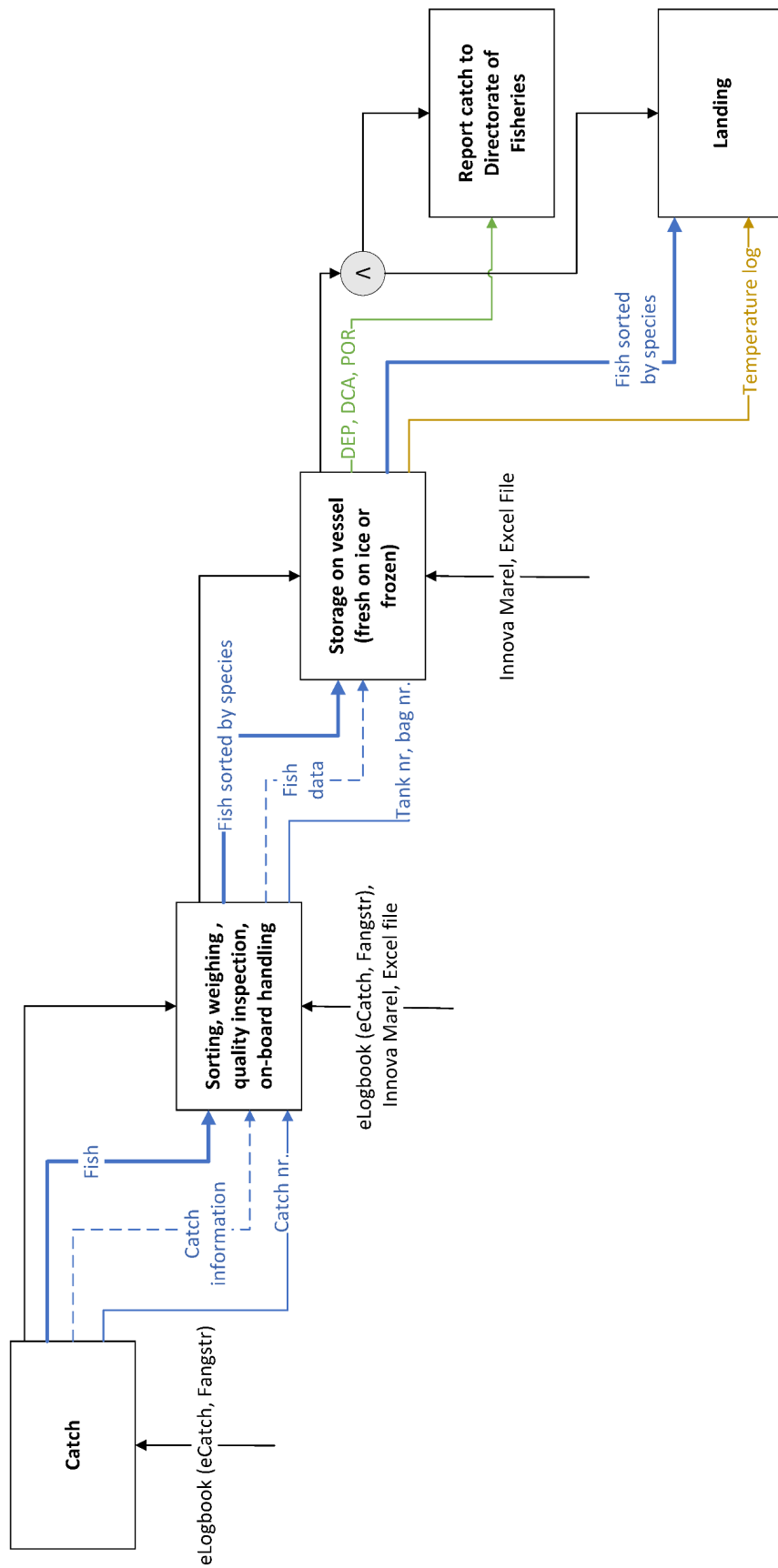

**Figure 5:** Information and material flow at the Catching operation.

**Table 1:** Relevant data recorded in the *Catching operation*.

Function	Relevant data recorded	Data system
Catch	Vessel name, trawling time, species, total weight, catch area, product condition, trawling position (start and end)	eLogbook Example: Fangstr (earlier eCatch)
Sorting, weighing, quality inspection, on-board handling	Weight per species, quality control	Excel or Inova by Marel
Storage on vessel (fresh on ice or frozen)	Freezing duration, Temperature in tank, Temperature in fish	Manual system, Excel or Inova by Marel
Reporting catch to The Directorate of Fisheries	<p>DEP: Port of departure, international code (ISO), time and date of departure, vessel name, registration nr., main fishing activity</p> <p>DCA: Catch area, geographical coordinates of start and end of catch, depth of start and end of catch, time (start and end) and date of catch, vessel name, registration nr., fishing permit/licence, fishing gear + specifications, total weight of catch, species, weight per species</p> <p>POR: Port of arrival, international code (ISO), name of landing facility, weight per species in kg for landed fish and for fish onboard in vessel</p>	ERS, VMS, Fangstr can also report this

#### 4.2.2 Landing

The *Landing* of the fish, as shown in Figure 6, includes the sale of fish, either through auction or direct sale at the quay. This function is divided into the subfunctions *Sale at Auction*, *Quality inspection*, *Direct Sale*, *Report to Fishermen's Sales Org.*, *Report to Directorate of Fisheries*, *Export* and *Landing at Processing Plant*.

It is the Fish Sales Act and the Marine Resources Act §48 that regulate the sale of all wild caught fish in Norway (Lovdata, 2013b, Lovdata, 2008). All sale of wild fish is organized by the Norwegian Fishermen's Sales Organization and it is illegal to trade wild caught fish outside of this organization.

The catching operation and processing are often done by different companies in Norway (Thakur and Gunnlaugsson, 2018). The fish is delivered either fresh or frozen to the processing plant. If the fish is sold directly to the buyer, the fish is graded by size and quality, and a sales note is written between the fishing crew and the processing company. The price is dependent on the fish quality.

If the fish is sold in auctions, the buyers have no chance to see the fish before bidding as auctions are digital and the fish is sold before landing (Sogn-Grundvåg et al., 2019). The buyers therefore rely on detailed information about the fish quality and size before bidding. Buyers have access to a sales portal where information about the auctions are available. The prices on the fish are only available to the fishing crew and the buyers. The only information that is required to be public is the vessel name, vessel register mark, name of the processing plant, species, and weight per species. Pelagic fish is mostly sold through auctions, and Norsk Sildesalgslag (NSS) publishes the relevant information on the fish on their webpages. They wish to keep auctions transparent and therefore publish more information about the fish, including quality indicators such as bait and bruises.

Fish exported to the EU are required to have a Catch certificate (Catch Certificate, 2017). The catch certificates have the aim of preventing the sale of IUU fish products in the EU. This document includes information about the species caught, their product code, the weight per species as well as total weight, the name and registration number of the vessel, the catch area, the landing date, and the sales note number.

Catch certificates can be signed electronically in the CatchSign App. Catch Certificate SA, owned by the Norwegian Fishermen's Sales Organization, are the responsible organization for issuing catch certificates.

If the fish is not sold or exported at landing, a landing note is written, and the frozen fish is usually placed in storage until sold. Both the fishing company and buyer are responsible for writing the sales note, which has to be sent to the Directorate of Fisheries and the Norwegian Fishermen's Sales Organization in an XML-format (Lovdata, 2014a). The landing and sales notes are published at the Directorate of Fisheries' webpage 12 months after the catch was landed. There are several companies that deliver electronics sales notes, e.g., Wise Blue AS (Wise Blue Connector), Maritech Systems AS, Marel Norge AS, TreC Fisk AS and K2 Solutions (Multipack). These systems can automatically register data on the products, species, product condition, conservation, quality, sizes, vessel information, fishing gear, catch area, transport modes, packaging information.

The sales note serves several purposes. It contains the receipt for the buyer and the guaranteed payment to the fishing crew. It is also a part of Norway's official catch statistics where that the total amount of fish caught is recorded and controlled. This information is used to estimate the current size of the fish populations, to determine the fishing quotas, and the environmental certifications of the fish.

The relevant data recorded in the quality inspection, the landing/sales notes and catch certificate are presented in Table 2.

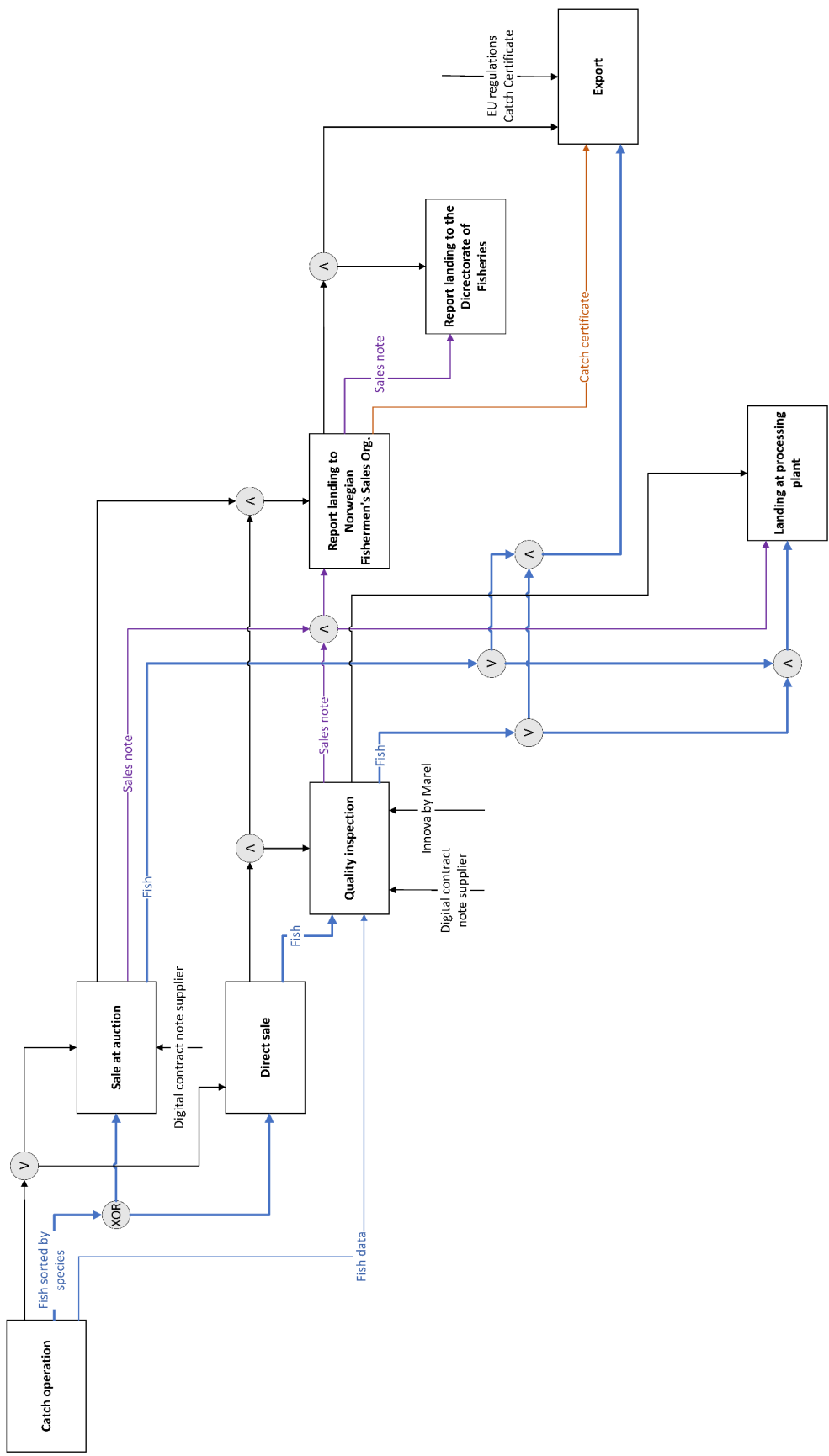

Figure 6: Information and material flow at Landing.

**Table 2:** Relevant data recorded in *Landing*.

Function	Relevant data recorded	Data system / Document
Quality inspection	Registered date, responsible person catch information: vessel, production code /lot no., first day of catch, catch area ICES, approved onboard cooling documentation according to FOR-2008-12-22-1624, confirmed onboard transportation time according to FOR-2008-12-22-1624 MSC certification Quality control, raw material: time of inspection, grading, Core temperature, feed, belly, bruises, freshness, anisakis Quality control, finished product: product, grading, cut of fish (tail or centre), colour, bruises, bloodspots, texture, tail texture	Manual
Reporting to Norwegian Fishermen's Sales Organization	Vessel ID, vessel name, fishing company name, catch date, catch area, catch method, landing date, catch description (species, fresh/frozen, weight, size), price	Landing/sales note Electronic sales note suppliers: Wise Blue AS (Wise Blue Connector), Maritech Systems AS, Marel Norge AS, TreC Fisk AS and K2 Solutions (Multipack).
Export	Transport details: country of export, port / airport / other place of departure, vessel name and flag, flight number/airway bill number, truck nationality and reg. number, Railway bill number, other transport documents Description of exported products: species, product code, product CN code (if provided by exporter), product weight Exporter references: Name and address of exporter, signature, date Fishing vessel and catch details: fishing vessel name, registration number, catch area, landing date, sales note number	Catch certificate

### 4.2.3 Processing

Figure 7 shows the division on the *Processing* function into the subfunctions *Fish arrives at processing plant*, *Sorting by size and weight and quality inspection*, *Production planning*, *Filleting*, *Rest raw materials*, *Other processing*, *Palletizing and labelling*, *Selling fish to secondary processing*. The processed seafood products are then sent to *Transport for Retail*.

The buyer has access to the information available in the sales note and usually can get the temperature log and some supplementary information about the fish and the catch if asked. After the fish is landed it is processed into either fillet, rest raw materials, or other fish products at a processing plant. Many processing companies use the software Innova by Marel to record and store data during the processing steps. The fish

is packed and labelled before being transported either to retail or to industry customer for secondary processing to value-added products (fish soup, fish sticks etc). The software Maritech is used by several companies for labelling. The relevant data recorded in the *Processing* function is presented in Table 3.

The processing company is required to write a journal with information on every fish received (Lovdata, 2014a). The journal consists of two main parts: the landing and the transportation from each plant. The system requirements are that the journal must be electronic and that the information from the sales notes must be automatically connected to the journal. The producers can use a self-made system, an excel sheet or a professional software. They should be an integrated part of the company's production and planning system. It is required that the two parts of the journal can be retrieved separately, are stored, and accessible digitally. The main aim of the journal is to prevent illegal sale of fish.

When the fish leaves the processing plant the journal for transport must be filled out. This journal contains the date of transport out of the plant, the weight of the fish and the species, product condition and weight per species describes with number codes from The Directorate of Fisheries.

**Table 3:** Relevant data recorded in *Processing*.

<b>Function</b>	<b>Relevant recorded data</b>	<b>Data system</b>
Journal on arriving at processing plant	Date of landing Species, Product condition, Weight per species, Total weight landed, Number of fish, Number of fish weighed, Average weight If processed: Fish owner e.g., processing plant name and org. no., transporter name, transport method Else: vessel name, register mark of vessel, Sales note no.	Excel or electronic
Sorting by size and weight, and quality inspection	Batch ID, date, size, weight, quality grade	Innova by Marel
Filleting	Temperature, product type, weight	Innova by Marel
Other processing	Temperature, product type, weight	Innova by Marel
Rest raw material	Temperature, product type, weight	Innova by Marel
Packaging of finished products	GTIN, Species, Catch area, Lot number, Size, Treatment, Quality, Preservation (fresh/frozen), Packing date, best before date, Net weight, Box number, Pallet number, Catch method	Maritech
Palletizing and labelling	SSCC, Pallet number, Order number, Species, Treatment, Size, Number of boxes, Weight per box	Maritech system
Journal on Transport from processing plant	Date of transport, Name of plant, Name of transporter, Registration mark of transport, Contract note no. if the fish is not processed. Species, Product condition, Weight per species, Total weight	Excel or electronic



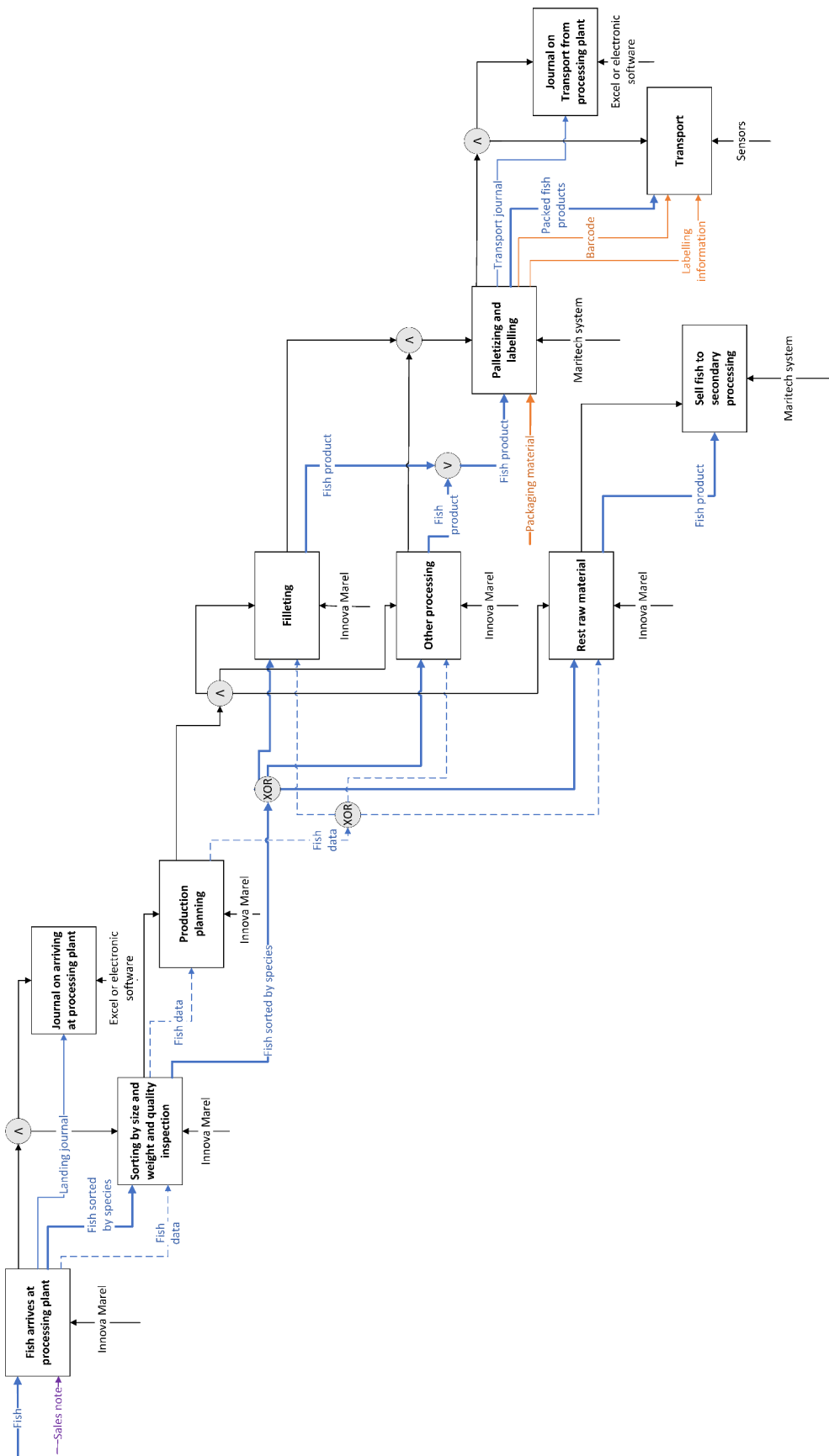

Figure 7: Information and material flow at *Processing*.

#### 4.2.4 Transport

Transport and storage of food is regulated by the Norwegian Food Safety Authority (NFSA) and the Act of quality on Fish and Fish Products (Lovdata, 2013a, Norwegian Food Safety Authority, 2014). The company responsible for transport is required to monitor the temperature of the fish, and to document that the cold chain has not been broken (Norwegian Food Safety Authority, 2016, Lovdata, 2021, Spurkeland, 2021). If the products are frozen, sensors that automatically monitor temperature are required. The transport routes and modes are usually not communicated to the consumers.

#### 4.2.5 Retail

The general requirements of food labelling for food and specifically for seafood in Norway are summarized in Table 4. The labelling requirement of food are regulated by the Act of Food Information to the Consumers and NFSA (Norwegian Food Safety Authority, 2014, Lovdata, 2014b). The information about the fish is either labelled on packed product or printed on labels for fresh products. Even though some companies provide additional information on their website, the information on the label is considered the communicated information to the consumer, unless they provide a tag that the consumers can scan and lead them directly to the additional information. If the products are exported to the EU, EU requirements for food labelling applies as presented in Figure 8 and 9.

**Table 4:** General and specific requirements for food labelling in Norway.

Requirements	Information
General information required for food labelling in Norway	Commercial designation and scientific names Production method Net quantity Ingredients (proportion of main ingredients, allergens in bold) Nutrient information per unit Shelf life – “Best before” date or “Use by” date Responsible food business operator Information on storage and use Production date – (catch date for fish) Freezing date (if different from production date)
Specific information for labelling of seafood in Norway	Fish species Catch area or country of origin Fishing gear Catch date Slaughter date (fresh fish products) Production date Freezing date (if different from production date) Temperature (not canned fish) Identification mark (EFTA)



**Figure 8:** Example of food label with EU requirements and voluntary elements for a processed seafood product (European Commission, 2015).

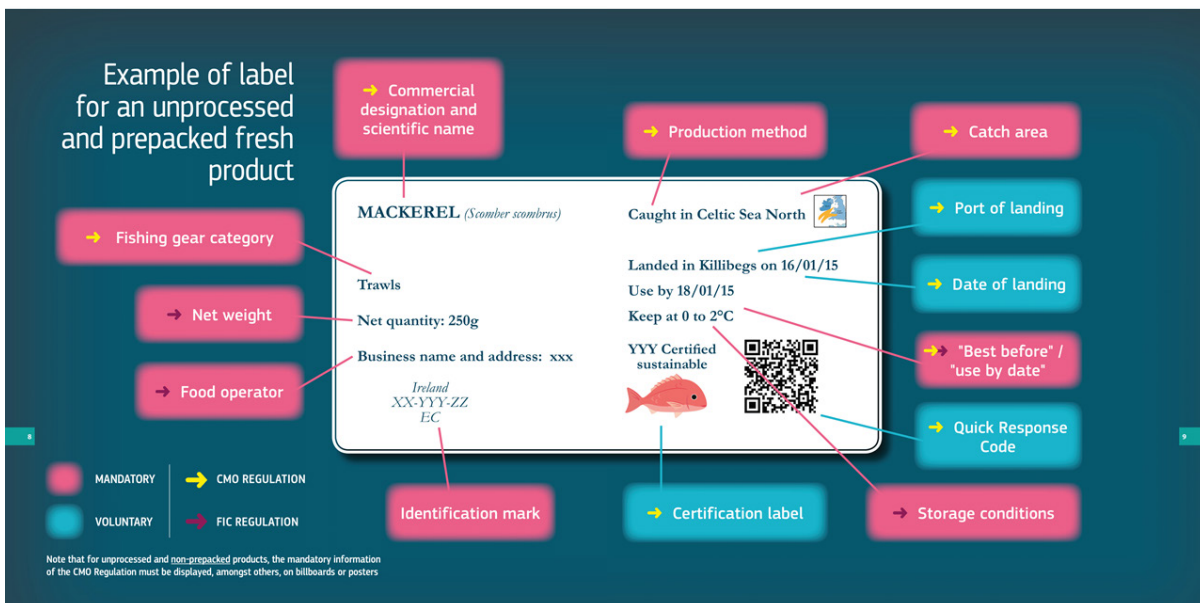

**Figure 9:** Example of food label with EU requirements and voluntary elements for an unprocessed fresh seafood product (European Commission, 2015).

### 4.3 Certificates and standards for sustainability and traceability of wild caught fish

The most known certification for proving the sustainability of wild caught fish is the Marine Stewardship Council (MSC) certifications. The MSC Fisheries Standard ensures that the fish harvested is from sustainable stocks, that the environmental impacts are minimal and that the fisheries operations are well managed (MSCa). However, environmental impacts due to fuel and energy consumption are not included in the assessment. In Norway, 15 species are MSC certified (Kvile, 2021). An independent third-party, Conformity Assessment Bodies, assesses if the fisheries qualify for this certification. The MSC Chain of Custody standard assesses every food business operator in the food supply chain and requires that certified products are traceable to a sustainable source (MSCb).

ISO published a standard in 2011 for traceability of wild captured fish (ISO 12875:2011). This standard specifies how fish products are to be identified and what information is to be captured and stored by the food business operators in the supply chains. The fisheries industry in Norway is also developing its own standard for Norwegian sustainable fisheries, the Norwegian Responsible Fisheries Management (NRFM) (Svorken, 2021).

A new European standard, NS-EN 17099:2020, for labelling of fish boxes was established in 2020. This standard replaces the Norwegian standard, NS 9405:2014, and includes the new EU regulations on seafood labelling and traceability (Standard Norge, 2020). It states that the catch date, packaging date, catching area with FAO code must be available on the label. The 2D GS1 Datamatrix have replaced the linear barcodes on the labels (Menkerud, 2020). Another notable change in the label is that the catch area from the old standard has been removed. New information required on the labels are expiration date, species, series number (unique box/ number), catch area (FAO code), catch date, production method, and approval number for processor. The new and the old labels are presented in Figure 10.



Figure 10: Old and new labels for fish boxes (Menkerud, 2020).

#### 4.4 Regulations on seafood traceability

Current regulations on traceability have a one step up-one step down approach (Lovdata, 2005). Each food business operator is required to know where they received the product and where it is going to. The background of this regulation is to be able to trace the fish in cases of compromised food safety, e.g., the food is contaminated or contains parasites, as it is illegal to sell food products that are not safe for consumption. Other key points of traceability are to give correct information about the product and its origin, tackle events related to compromised food safety, sustain competition between food business operators and counteract food fraud.

#### 4.5 Information exchange practices in the fisheries supply chain

There is a smooth exchange of information from the fishing vessels to the Directorate of Fisheries and the Norwegian Fishermen's sales organizations. Several operators have electronic systems in place that automatically send the necessary information to the regulatory authorities. Both the *Catch operation* and *Processing* of the fish use advanced software to store, track and analyse their data. However, there is little to no information exchange between the processors and the fishing vessels on the quality of the fish (Thakur and Gunnlaugsson, 2018). This might be because these operations are often handled by different companies in Norway.

The operators interviewed in this study pointed to a lack of willingness in sharing data as the biggest challenge to increase the information shared in the supply chain. Although, there are several technological challenges as well. Not all companies have come as far as to automatize information sharing with electronic

traceability systems, and some systems do not communicate automatically which then requires manual transfer of data. These are problems that can be fixed by either regulations or willingness and motivation of the industry itself. The fishing company interviewed, expressed a wish to have complete control over the whole supply chain, ensuring that their fish has a high quality and that the customers receive the correct product. However, increasing traceability and data capture internally in the catch operation would be a priority.

Several companies are taking steps to reduce emissions and becoming more sustainable. Having a well-functioning traceability system is essential to both document and communicate sustainability information to the consumers. Since there is often limited space on product packaging, some producers add a code, e.g., a QR code, that the consumer can scan or look up to read supplementary information about the product. There are several existing traceability tools such as the QR-tracking application provided by Norwegian King Crab. The king crabs are each tagged with a unique code when fished and are then sent for retail all over the world. The traceability tool is delivered by Maritech and allows the customers to track the individual crabs to when and where they were caught (on county level), and to see which crew member caught the crab (Norway King Crab, 2015).

Most of these tools are targeted towards the consumers and provide information about the origin of the product, specifically the catch area. Other information regarding the catch, processing and transport is usually not communicated. In some cases, more detailed information about the product, specifically about transport routes and processing, is available on the producer's web pages. This information could easily be added to an already existing traceability tool if processing and transport does not differ from the unique products. This will of course also depend on the granularity of the traceability tool, as reporting specific coordinates probably would change, but the general area of catch might be the same.

#### 4.6 Information gaps – transparency, traceability, and sustainability

It is not common practice to monitor and store data on fuel and energy consumption in any of the steps in the supply chain. For the catch operation, measuring these aspects would require advanced and expensive sensors. However, estimates and averages could be calculated for the different fishing gears and species, e.g., trawling vs. purse seining and cod vs. mackerel etc. (Ziegler et al., 2021). Some companies, as for example Icelandic BRIM, are already monitoring the speed and oil use and are working on converting this information into environmental indicators such as carbon footprint. One of the companies interviewed expressed a wish to track data on fuel and energy consumption, with the primary motivation of reducing their environmental impact, by optimising the production and gain insight on when to fish with the least impact. They also wanted to use this information to communicate the environmental impact of their products to the consumers. The cost of sensors required for these measurements were mentioned as one of the main barriers to implement this next level of data capture. Monitoring waste streams and bycatch are also important to reduce the environmental and biodiversity impacts of the fisheries industry (Moan et al., 2020).

#### 4.7 Stakeholder perspectives

Crew at fishing vessels report that they must guess the volume of catch that are being controlled on land and if it's not correct, they risk penalties. Having an authorized and automatic system is a fisherman's dream. Increased traceability will also give back control to the fishing crew, when mistakes in reporting due to human error is presented as fraud (The Directorate of Fisheries, 2021a).

If the fishing vessels reported the information on the fish quality to the processors, the processors could start the production planning before receiving the fish and thereby optimise production (Thakur and Gunnlaugsson, 2018). Based on the data collected in the processing plant, the fishing vessels could gain valuable insights in where and when to fish for optimal quality.

The transport routes and modes and fuel consumption are only known for the logistics companies and is not communicated to the consumers.

In Helsingborg municipality in Sweden, the authorities wanted more knowledge on where the seafood comes from, after discovering that the imported cod had a detour to China and was not arriving directly from Norway. Their demand of product origin and processing and transport history was the background for a pilot that uses a blockchain based traceability system, so that the consumers can track every step the fish takes from catch to fork (Sjømatbedriftene, 2021). A report on seafood consumer trends stated that consumers are willing to pay up to 35% more if producers can document sustainability of the product (Norwegian Seafood Council, 2021b, The Directorate of Fisheries, 2021a). It is however worth noting that the term “sustainable” has different cultural interpretation. It can mean organic, healthy, and local, as well as having minimised environmental impacts and a low carbon footprint.

#### 4.8 Novel technologies and traceability examples in the fisheries industry

The Directorate of Fisheries have initiated the FangstID program that aims to use technological solutions on-board fishing vessels to ensure correct recording of the catch operation (The Directorate of Fisheries, 2021a). The project started in 2021 with a goal that every fishing vessel can automatically register and report the fish caught to the Directorate of Fisheries. Today, the crew estimates the volume of fish caught on-board the fishing vessel and reports this amount, while controls happen on land. The crew then risk penalties if the volume estimated is different from the controlled volume. Implementation of this system can lower the amount of time used on reporting from the fishing crew's side.

Several companies are now looking into traceability systems that can trace seafood products from catch to fork with the use of the distributed ledger technology blockchain (Olsen et al., 2019). Blockchain is a digital recording of transactions or information. Every user has a copy of the blockchain and the information within the blockchain cannot be changed or overwritten. New information is added as a new block in the blockchain. However, some information is regarded sensitive, such as names of the fishing crew and prices of the fish and is not essential information for the consumers. Another crucial point is to keep track of the ownership of data. Each food business operator should keep ownership of their data, even though it is shared with other operators and customers in the supply chain. This technology allows for swift information exchange between different food business operators, and in cases of diminished food safety, history of the product can be easily retrieved. Another advantage is that this technology can communicate with more advanced Internet of Things (IoT) sensors, that could measure real-time fuel and energy consumption. If sensors were included over the whole supply chain, the complete carbon footprint of the seafood product could be calculated.

### 5 Conclusion and further work

The challenge with the one-up one-down approach to product traceability is that no operators have control over the complete supply chain. The more complex the supply chain is, the more time consuming it is to trace the product history. Increasing the amount of data recorded and shared in the fisheries supply chain could increase quality of the seafood products as well as reducing the emissions. Especially more information on environmental data should be estimated and communicated in a comprehensible form (e.g., environmental indicators such as carbon footprint) to the consumers of seafood products, at least for individual steps in the supply chain such as the catch operation. Transport routes and mode should be easily accessible for consumers as this is demanded knowledge. This information could be accessible through QR-codes or other labels connected to the fish products. Next steps for the industry could include the use of more advanced technology with sensors over the whole supply chain that could measure real-time data on energy and fuel consumption and calculate the emissions from the different steps in the supply chain. This could enhance the sustainability of the products by allowing the producers to gain insight in where they

could reduce emissions and waste streams. If this information is shared, in the form of understandable sustainability indicators, it can help consumers choose the most sustainable products.

Next steps and further work can include:

- Increasing the capture of sustainability data such as energy use, electricity, and fuel use, for example with the use of more advanced sensors.
- Documenting the recorded sustainability data both for internal use to reduce emissions and environmental impacts as well as communicating this information to customers and end-consumers.
- Increasing both up-stream and down-stream information sharing so that all actors in the supply chain know the history of the product and where it is going. The transport routes and modes can also be communicated to the consumers.
- The external traceability between operators in the fisheries supply chain should be improved, especially between vessels and processors on fish quality information as this could have potential benefits both for the processors and the fishing vessels.
- There is also a need for a standardisation of data capture and communication of the data. This standardisation should include which information to capture at each step in the supply chain and how to store it. This work must be a collaborative effort between the fisheries sector, solution providers, research experts and regulatory bodies.
- Sustainability information could be presented as standardised sustainability indicators for external communication.

## 6 Bibliography

- CATCH CERTIFICATE. 2017. *Fangstsertifikat* [Online]. Available: <https://www.catchcertificate.no/agreed-record/skjemaer/fangstsertifikat/> [Accessed 20.10 2021].
- EUROPEAN COMMISSION 2015. A pocket guide to the EU's new fish and aquaculture consumer labels
- EUROPEAN COMMISSION 2018. The EU Food Fraud Network and the System for Administrative Assistance - Food Fraud. *Annual Report 2018*. .
- HJELLNES, V., RUSTAD, T. & FALCH, E. 2020. The value chain of the white fish industry in Norway: History, current status and possibilities for improvement–A review. *Regional Studies in Marine Science*, 36, 101293.
- ISLAM, S., CULLEN, J. M. & MANNING, L. 2021. Visualising food traceability systems: A novel system architecture for mapping material and information flow. *Trends in Food Science & Technology*.
- ISO 12875:2011 Traceability of finfish products -Specification on the information to be recorded in captured finfish distribution chains
- KARLSEN, K. M., DREYER, B., OLSEN, P. & ELVEVOLL, E. O. 2012. Granularity and its role in implementation of seafood traceability. *Journal of Food Engineering*, 112, 78-85.
- KVILE, K. 2021. Seks norske fiskerier har mistet miljøsertifisering på to år *Fiskeribladet*.
- LEAHY, S. 2021. Revealed: seafood fraud happening on a vast scale. *The Guardian*
- LOVDATA 2005. Forskrift om sporbarhet av næringsmidler og fôr.
- LOVDATA 2008. Lov om forvaltning av viltlevande marine ressursar (havressurslova).
- LOVDATA 2013a. Forskrift om kvalitet på fisk og fiskevarer
- LOVDATA 2013b. Lov om førstehandsomsetning av viltlevande marine ressursar (fiskeslagslova).
- LOVDATA 2014a. Forskrift om landings- og sluttseddel (landingsforskriften).
- LOVDATA 2014b. Forskrift om matinformasjon til forbrukerne (matinformasjonsforskriften)
- LOVDATA 2021. Forskrifter om internasjonal transport av lett bedervelige næringsmidler.
- MENKERUD, T. 2020. NS-EN 17099:2020 Informasjonsteknologi - Fiskeri- og akvakulturprodukter -Krav til etikettering av distribusjonseenheter og paller i handel med fiskeri- og akvakulturprodukter. *In: NORWAY, G. (ed.)*.
- MERRIFIELD, M., GLEASON, M., BELLQUIST, L., KAUER, K., OBERHOFF, D., BURT, C., REINECKE, S. & BELL, M. 2019. eCatch: Enabling collaborative fisheries management with technology. *Ecological Informatics*, 52, 82-93.
- MOAN, A., SKERN-MAURITZEN, M., VØLSTAD, J. H. & BJØRGE, A. 2020. Assessing the impact of fisheries-related mortality of harbour porpoise (*Phocoena phocoena*) caused by incidental bycatch in the dynamic Norwegian gillnet fisheries. *ICES Journal of Marine Science*, 77, 3039-3049.
- MOE, T. 1998. Perspectives on traceability in food manufacture. *Trends in Food Science & Technology*, 9, 211-214.
- MSCA. *The MSC Fisheries Standard* [Online]. Available: <https://www.msc.org/standards-and-certification/fisheries-standard> [Accessed 20.10 2021].
- MSCB. *The MSC Chain of Custody Standard* [Online]. Available: <https://www.msc.org/standards-and-certification/chain-of-custody-standard> [Accessed 20.10 2021].
- NORWAY KING CRAB. 2015. *YOUR KING CRAB - 1004070* [Online]. Available: <https://nkc.no/track/?id=1004070> [Accessed 26.10 2021].
- NORWEGIAN FOOD SAFETY AUTHORITY 2014. Veileder - Særskilte merkebestemmelser fisk og fiskevarer
- NORWEGIAN FOOD SAFETY AUTHORITY. 2016. *Krav til transport av mat* [Online]. Available: [https://www.mattilsynet.no/mat\\_og\\_vann/transport\\_og\\_lager/frakt\\_og\\_transport/krav\\_til\\_transport\\_av\\_mat.4547](https://www.mattilsynet.no/mat_og_vann/transport_og_lager/frakt_og_transport/krav_til_transport_av_mat.4547) [Accessed 22.10 2021].
- NORWEGIAN SEAFOOD COUNCIL. 2021a. *Nøkkeltall* [Online]. Available: <https://seafood.no/markedsinnsikt/nokkeltall/> [Accessed 18.11 2021].
- NORWEGIAN SEAFOOD COUNCIL 2021b. Top Seafood Consumer Trends 2021.
- OLSEN, P. & BORIT, M. 2013. How to define traceability. *Trends in food science & technology*, 29, 142-150.





- OLSEN, P., BORIT, M. & SYED, S. 2019. Applications, limitations, costs, and benefits related to the use of blockchain technology in the food industry. *Nofima rapportserie*.
- SJØMATBEDRIFTENE. 2021. Helsingborg kommune - første kommune i verden som sporer torsk
- SOGN-GRUNDVÅG, G., ZHANG, D. & IVERSEN, A. 2019. Large buyers at a fish auction: The case of the Norwegian pelagic auction. *Marine Policy*, 104, 232-238.
- SPURKELAND, E. 2021. Termotransport. *Store norske leksikon*, . Store norske leksikon, .
- STANDARD NORGE. 2020. *Sporbarheten til sjømatprodukter -Merking av fiskekasser* [Online]. Available: <https://www.standard.no/nyheter/nyhetsarkiv/fiskeri-akvakultur-og-mat/2020-nyheter/sporbarheten-til-sjomatprodukter---merking-av-fiskekasser/> [Accessed 22.11 2021].
- SVORKEN, M. 2021. Norwegian Responsible Fisheries Management (NRFM)–Utvikling av norsk standard for bærekraftige fiskerier. *Nofima rapportserie*.
- THAKUR, M. & GUNNLAUGSSON, V. N. 2018. Information sharing strategies in whitefish supply chains in Norway vs. Iceland: impact on supply chain decision making. *International Journal on Food System Dynamics*, 9, 240-252.
- THE DIRECTORATE OF FISHERIES. 2020. *Rundvekt (tonn) fordelt på art* [Online]. Available: <https://www.fiskeridir.no/Yrkesfiske/Tall-og-analyse/Fangst-og-kvoter/Fangst/Fangst-fordelt-paa-art> [Accessed 18.11 2021].
- THE DIRECTORATE OF FISHERIES 2021a. FangstID webinar 28. april.
- THE DIRECTORATE OF FISHERIES 2021b. J-168-2021: Forskrift om posisjonsrapportering og elektroniske rapportering for norske fiske- og fangstfartøy (ERS-forskriften)
- TRONDSSEN, T. 2012. Value chains, business conventions, and market adaptation: A comparative analysis of Norwegian and Icelandic fish exports. *The Canadian Geographer/Le Géographe canadien*, 56, 459-473.
- WANG, X. & LI, D. Value added on food traceability: a supply chain management approach. 2006 IEEE International Conference on Service Operations and Logistics, and Informatics, 2006. IEEE, 493-498.
- ZIEGLER, F., JAFARZADEH, S., SKONTORP HOGNES, E. & WINTHER, U. 2021. Greenhouse gas emissions of Norwegian seafoods: From comprehensive to simplified assessment. *Journal of Industrial Ecology*, 1-12.

## 7 Appendix

### 7.1 Interview guide

- **Relevant for all functions**
  - Format of data
  - Data system used or manual system and data storage
  - Data sharing practices – what data is shared and how?
  
- **What data is captured on the vessel?**
  - Name of the vessel
  - Register mark
  - Time of catch (start and end)
  - Geographic area of catch
  - Geographic coordinates of catch (start and end)
  - Fishing gear
  - Problems with gear
  - Fishing gear specifications
  - Total weight of catch
  - Species
  - Weight per species
  - By-catch
  - Quality indications (blood, bruises, bait etc.)
  - Conservation methods (iced, frozen, seawater)
  - Energy and fuel consumption
  - Other information not mentioned
  - How is the fish/catch marked with traceable units?
  
- **What data is shared with processing plant?**
  
- **What data is captured during processing?**
  - Quality indicators
  - Processing plant name
  - Finished product
  - Temperature
  - Other information
  
- **What data is collected under transport?**
  - Fuel consumption
  - Temperature
  
- **What data is communicated to retail?**

## 7.2 Information provided by the Norwegian Fishermen's Sales Organizations

**Table 5:** Information Norwegian Fishermen's Sales Organizations

Norwegian Fishermen's Sales Organizations	Fishtype	Information available
Required to publish	Whitefish Pelagic	Vessel name Vessel register mark Plant name Species Weight per species
Norges Sildesalgslag	Pelagic	Vessel name Time Date Area Plant name Buyer name Fishing gear Catch type (e.g. direct, pen frozen, meal and oil) Grid of net Species Usage (e.g. fishmeal, freezing) Quantity total Average weight per fish Assortment Bait – four qualitative categories
Norsk Råfisklag	Whitefish	Vessel register mark Vessel name Date (landing) Time (landing) Plant name Buyer name Geographic zone Quantity average Species Condition per species Average weight per fish Total weight per fish
Sunnmøre og Romsdals Fiskesalgslag (SUROFI)	Whitefish	Date Vessel register mark Vessel name Plant id Plant name Species Condition Conservation (e.g., frozen, iced) Total weight per species

Vest-Norges Fiskesalgslag	Whitefish	Vessel register mark Vessel name Plant name Catch area Landing date Total weight Species Total weight per species
Fishehav	Whitefish	Vessel name Catch area Plant name Landing date Species Conservation Weight per species

### 7.3 Example of the eCatch software

#### Screenshot of eCatch software

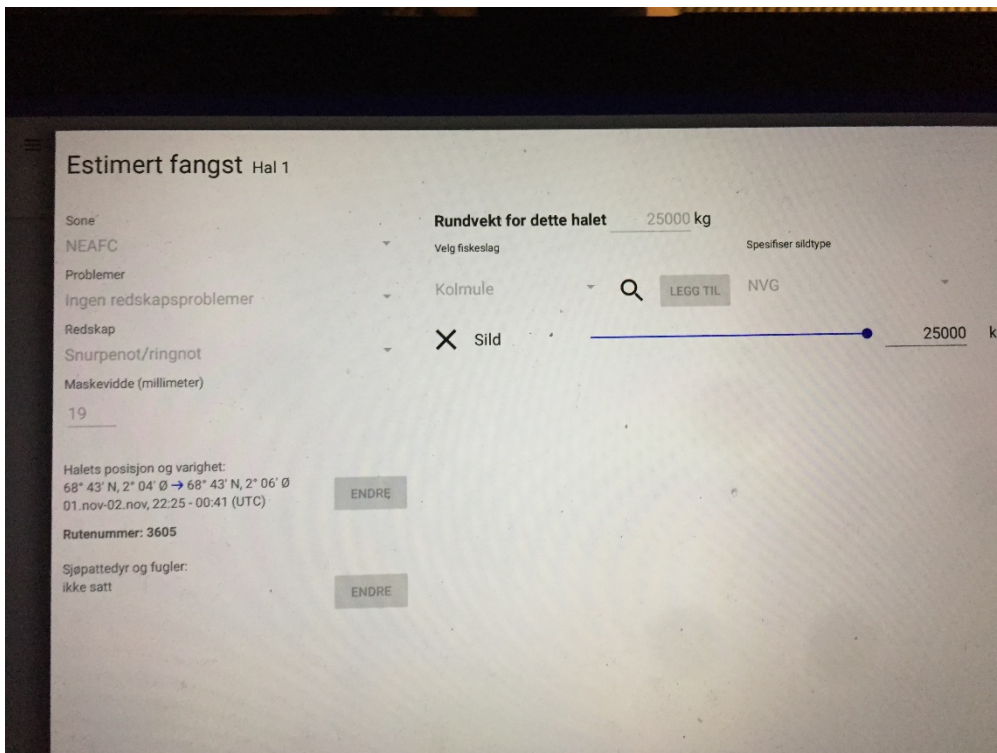

Figure 11: Screenshot from the eCatch software.